

UNIVERSITY OF SASKATCHEWAN
 EE456: Digital Communications
 FINAL EXAM, 9:00AM–12:00PM, December 9, 2008 (**closed-book**)
 Examiner: Ha H. Nguyen

Permitted Materials: Non-Programmable Calculator

There are 5 questions. All questions are of equal value (with part marks indicated) but not necessarily of equal difficulty. Full marks shall only be given to solutions that are properly explained and justified.

1. (*Class2K modulation*) Figure 1-(a) plots the 4 signals used in Miller modulation. Note that each signal has an energy of $E_b = V^2 T_b$. Figure 1-(b) shows the state diagram of Miller modulation, which tells us how a transmitted signal is generated based on the current input bit and the modulator's state. The error probability of the symbol-by-symbol demodulation of Miller signaling was derived (in the text and class) to be approximately $2Q\left(\sqrt{\frac{E_b}{N_0}}\right)$, where as usual $N_0/2$ is two-sided power spectral density of AWGN. The factor of 2 in the above expression arises from the fact that each bit has 2 nearest neighbors crowding it. To address this your friend suggests a modified state diagram in Figure 1-(c), which shall be called *Class2K* (class of 2000) modulation.

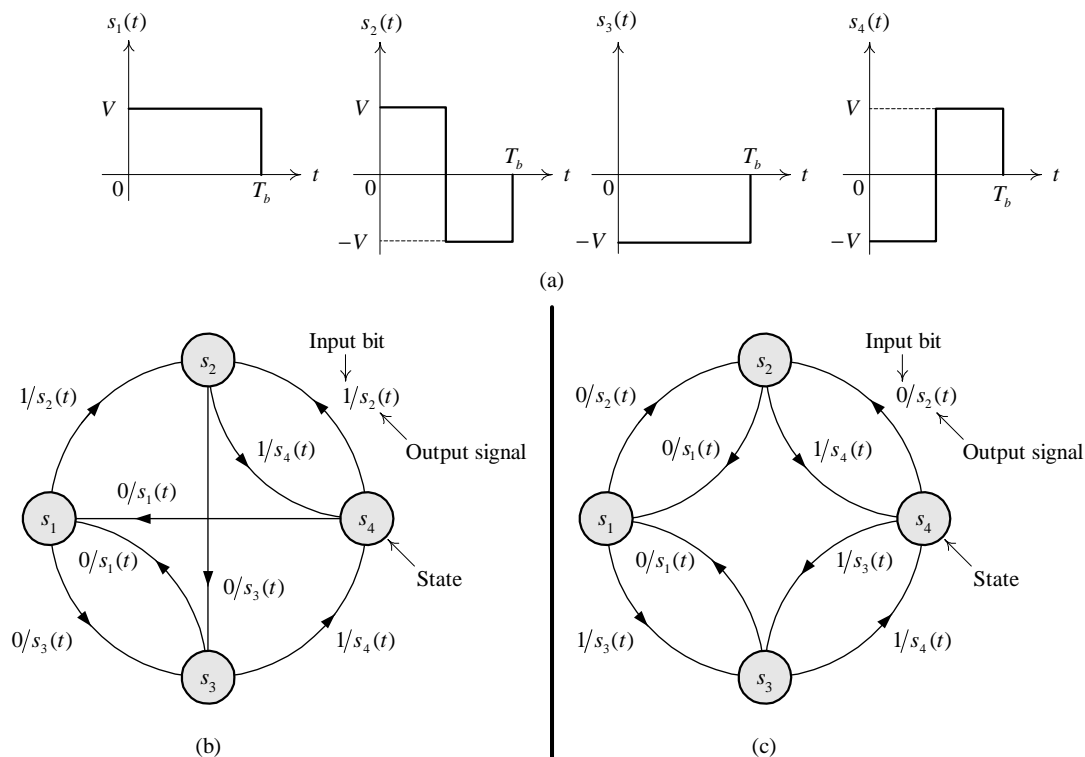

Figure 1: Signal set and state diagrams considered in Question 1.

- [1] (a) Comment on the synchronization capability of the Class2K modulation.
- [3] (b) Obtain a signal space representation of the signal set in Figure 1-(a) and label each signal with a bit 0 or 1 according to Figure 1-(c). Also draw the minimum distance boundary for the symbol-by-symbol demodulation.
- [2] (c) Determine the bit error probability of the symbol-by-symbol demodulation of the Class2K modulation. Compare it with that of Miller modulation and comment. *Hint:* It is useful to realize what is the equivalent decision boundary for the demodulation of bits 0 and 1.
- [2] (d) Start at state $s_1(t)$ at $t = 0$, draw the trellis diagram on the template provided in Figure 2.
- [2] (e) Let $E_b = 1$ joule. Suppose that the projections of the received signals onto $\phi_1(t)$ and $\phi_2(t)$ (that you chosen in Part (b)) over the first 3 bit intervals are given as

$$\left\{ r_1^{(1)} = -0.2, r_2^{(1)} = -0.4 \right\}, \left\{ r_1^{(2)} = +0.2, r_2^{(2)} = -0.8 \right\}, \left\{ r_1^{(3)} = +0.6, r_2^{(3)} = -0.4 \right\}$$

where the superscript k of $r_1^{(k)}, r_2^{(k)}$ signifies the bit interval. Using the Viterbi algorithm, determine the *survivor* paths at $t = 3T_b$. If you are to make the final decision on the first 3 information bits at this point, what would your decision be?

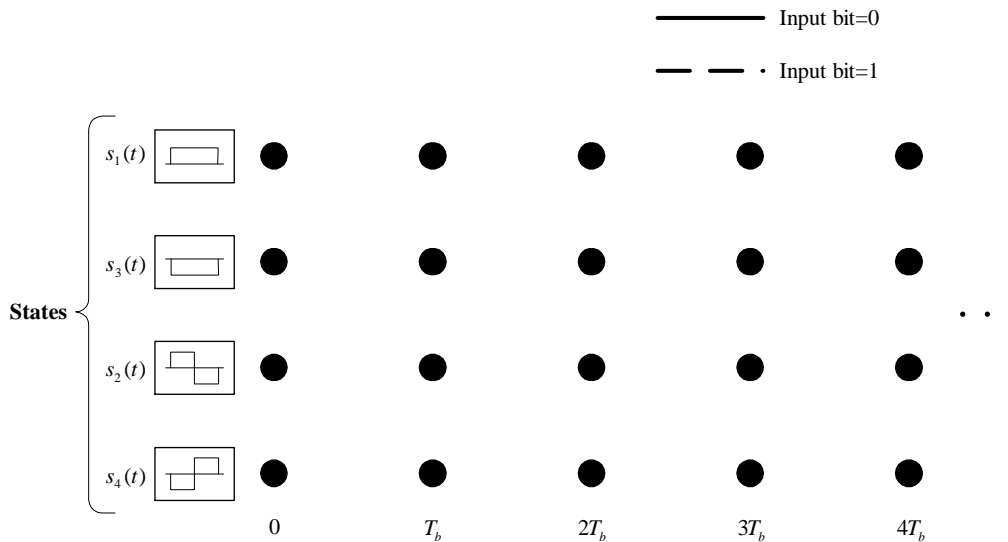

Figure 2: Template for trellis diagram in Question 1.

2. (*4-ASK modulation*) Figure 3 plots the NRZ-L and 4-ASK signals corresponding to ten information bits.

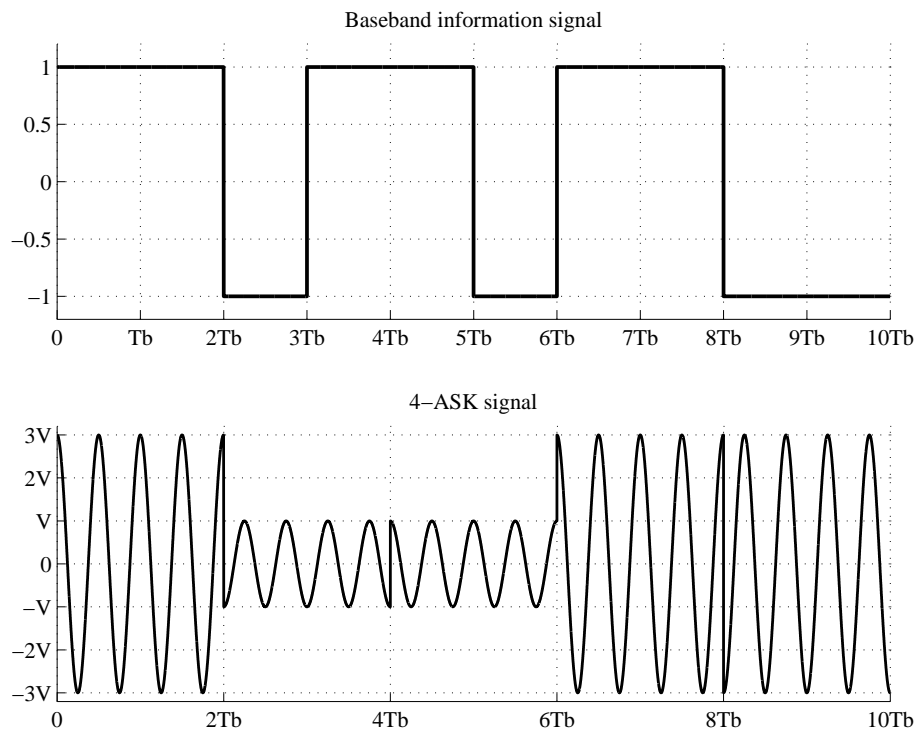

Figure 3: 4-ASK signal for Question 2.

- [3] (a) Let the carrier frequency be f_c . Obtain a signal space representation of the 4-ASK signal set used to generate the above 4-ASK waveform. Clearly indicate the energy of each signal in terms of V^2T_b . Also determine the minimum distance Δ of the constellation in terms of V^2T_b .
- [3] (b) Clearly indicate the mapping from 2 bits to one signal point in the signal space diagram obtained in (a). Is the mapping a Gray mapping? Explain.
- [2] (c) It is known that bits 0 and 1 are equally likely. Draw the optimum decision boundary for the detection of the *first* bit (i.e., the left bit in the mapping) associated with each ASK signal. Then determine the error probability of this bit in terms of the minimum distance Δ .
- [2] (d) Based on the result in (c), the error probability of the first bit is well approximated as $\frac{1}{2}Q\left(\frac{\Delta}{\sqrt{2N_0}}\right)$. Let $N_0 = 10^{-12}$ (watts/Hz), $V = 10$ mV. Determine the maximum transmission bit rate so that the error probability of the first bit is not higher than 10^{-6} . Note that $Q^{-1}(2 \times 10^{-6}) = 4.61$.

3. (*8-ary constellations*) Consider four 8-ary signal constellations in Figure 4, where all the signal points in each constellation are equally probable.

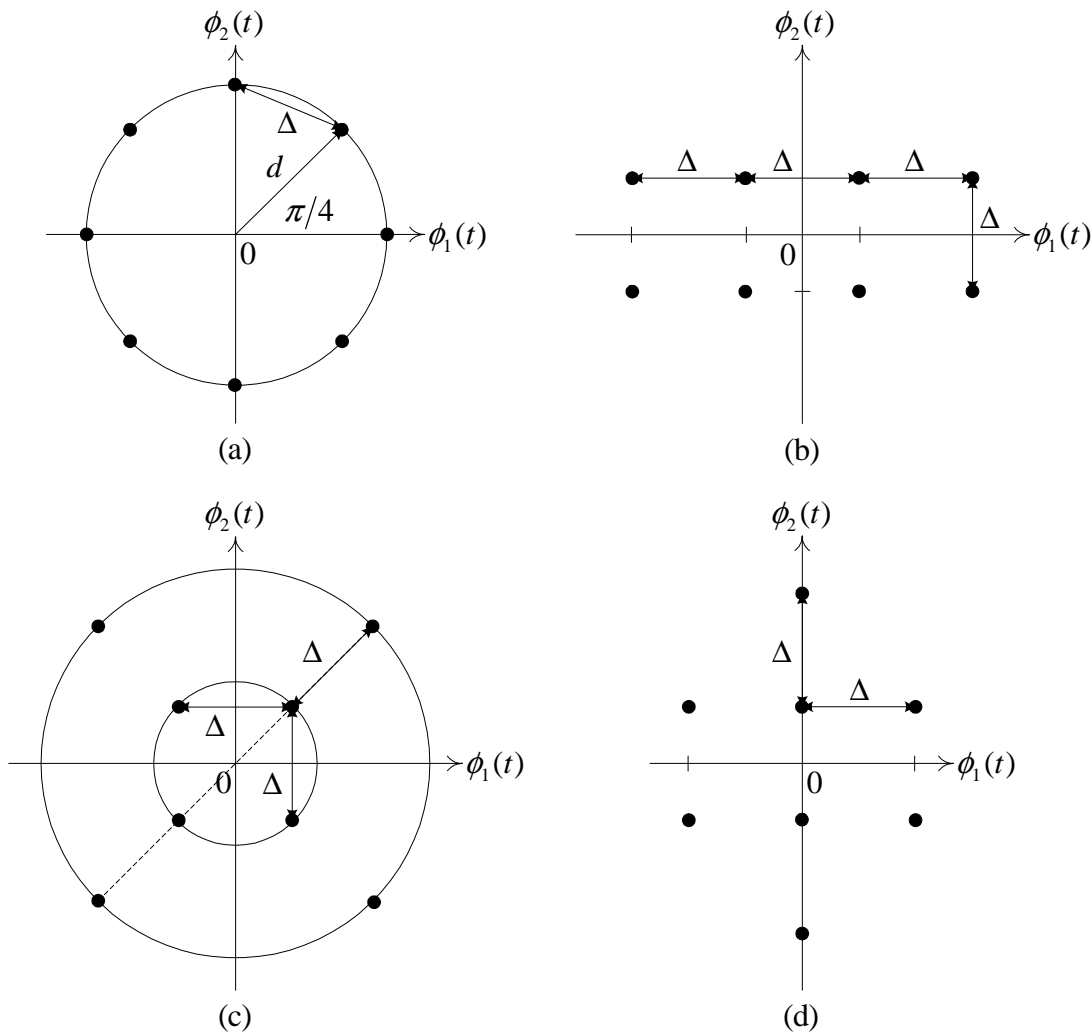

Figure 4: 8-ary constellations considered in Question 3.

- [5] (a) What can you say (roughly) about the symbol error performance of the four constellations and why? Compute the average energies for the four constellations and rank the signal constellations in terms of energy efficiency.
- [2] (b) Specify Gray mapping for constellation (b).
- [3] (c) Neatly draw the minimum-distance decision boundaries for signal constellation (d). Which signals in this constellation are *most* susceptible to error and why?

4. (*ISI*) Satellite channels can be well modeled as band-limited AWGN channels. Consider a 30MHz satellite channel in the Ku-band, whose transfer function is shown in Fig. 5. This channel has been used for digital video broadcasting via satellite (DVB-S and DVB-S2 standards).

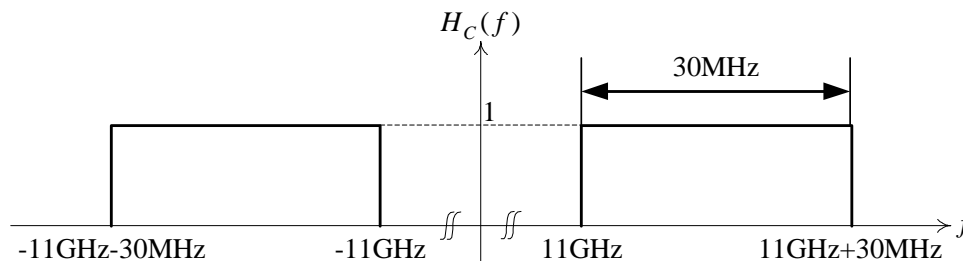

Figure 5: Transfer function of DVB-S/DVB-S2 channel.

- [6] (a) The first generation standard, DVB-S, specifies only QPSK modulation and a roll-off factor $\beta = 0.35$. What is the maximum bit rate supported by DVB-S that can avoid ISI? Explain your answer by clearly plotting the overall spectrum of the signal (i.e., after the receive filter). Identify all the relevant frequencies.
- [4] (b) The second generation standard, DVB-S2, supports a variety of modulation formats, namely QPSK, 8PSK, 16APSK and 32APSK. It also has three roll-off factor choices of $\beta = 0.35$, $\beta = 0.25$ and $\beta = 0.20$. What is the **maximum bit rate** that can be offered by DVB-S2 such that ISI is avoided? Clearly explain your answer. Compare it with the maximum rate of DVB-S and comment.

Hint: The frequency-domain Nyquist's zero-ISI criterion for *passband* channel is illustrated in Figure 6, where T_s is the designed symbol interval. It is mathematically stated as follows:

$$\sum_{k=-\infty}^{\infty} S_R \left(f + \frac{k}{T_s} \right) = \text{constant for } -\infty < f < \infty.$$

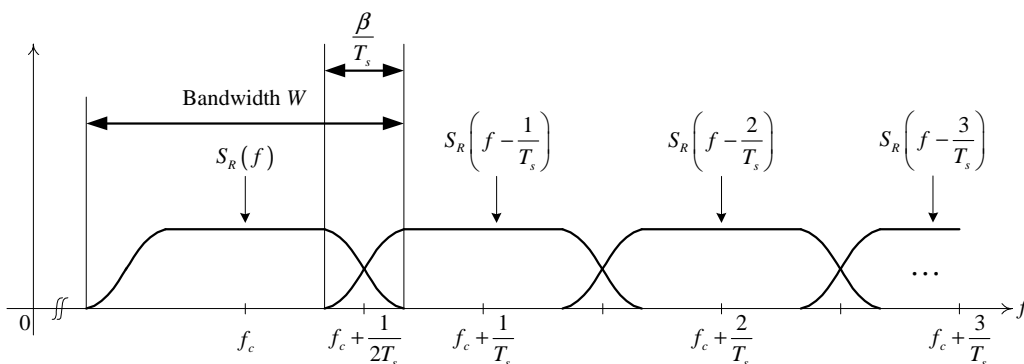

Figure 6: Nyquist's zero-ISI criterion for *passband* channel.

5. Do either (a) or (b). If you do both, the part with higher mark will be counted. [10]

- (a) Discuss (using block diagram) signal transmission through the band-limited channel. The discussion should include the following:
- * The need for modeling channels as being band-limited.
 - * The phenomenon called inter-symbol interference (ISI).
 - * The Nyquist's first criterion to achieve zero-ISI and its implications to the transmission rate and filter implementation issue.
- (b) Describe and compare M -QAM and M -FSK modulation techniques. The description and comparison should concentrate on signal constellation, receiver implementation, behavior of the bit error performance as M increases, and bandwidth and power efficiencies (refer to Figure 7). What modulation schemes are suitable for band-limited and power-limited channels respectively? Explain.

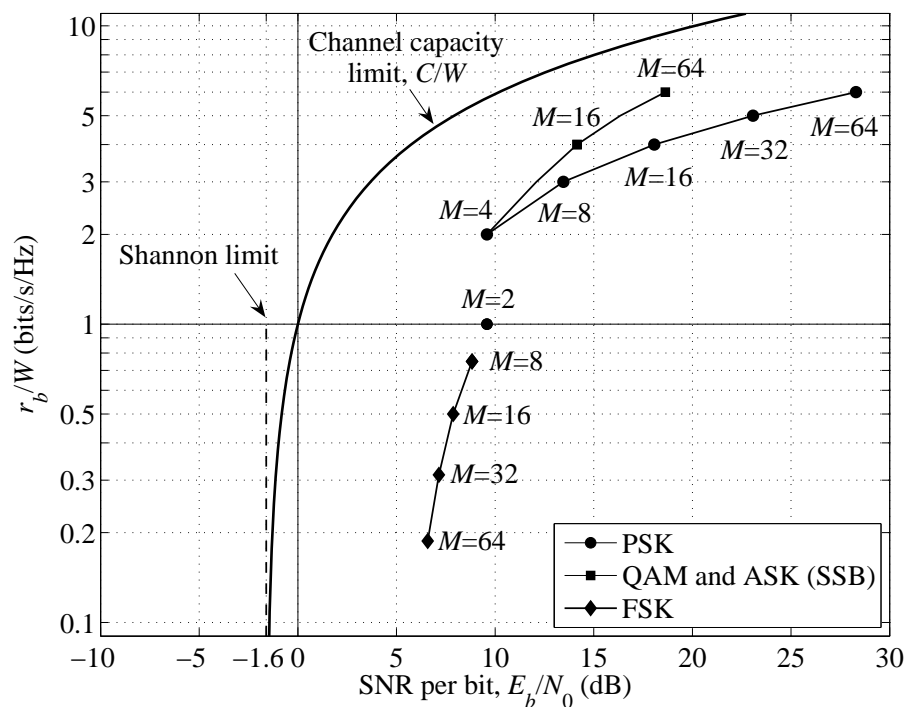

Figure 7: Comparison of different M -ary signaling techniques at *symbol error probability* of 10^{-5} . Note that the values of M shown next to square markers are for QAM. For SSB-ASK, take the square roots of these values.

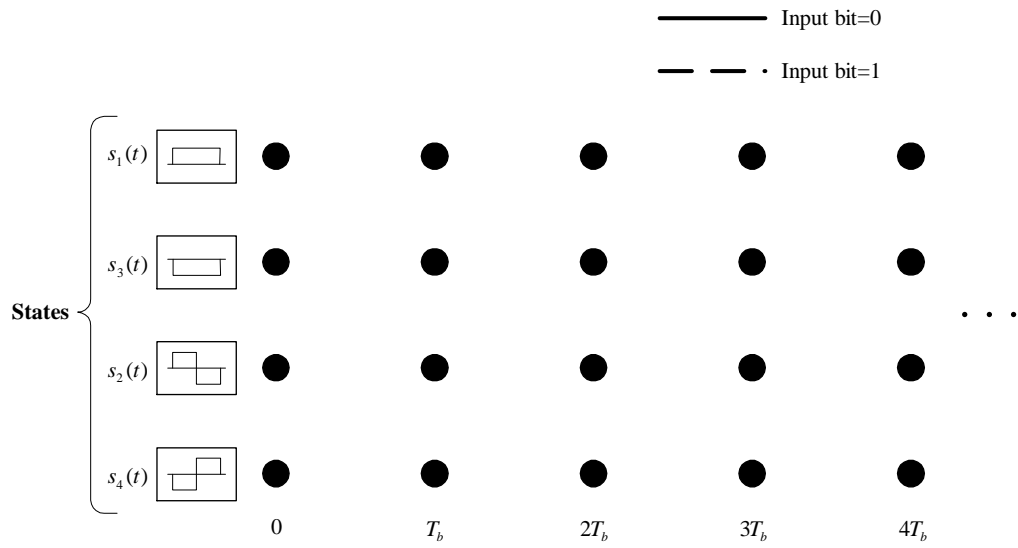

Figure 8: Template for trellis diagram in Question 1.

EE810 students do the below question instead of Question 5 on page 6.

5. (*A ternary communication system*) Three messages m_1 , m_2 and m_3 can be broadcasted by transmitting one of three signals, $s(t)$, 0 , or $-s(t)$ every T seconds, respectively. The received signals is

$$\mathbf{r}(t) = \begin{cases} s(t) + \mathbf{w}(t), & \text{if } m_1 \text{ is broadcasted} \\ \mathbf{w}(t), & \text{if } m_2 \text{ is broadcasted} \\ -s(t) + \mathbf{w}(t), & \text{if } m_3 \text{ is broadcasted} \end{cases}, \quad (1)$$

where $\mathbf{w}(t)$ is white Gaussian noise with zero mean and power spectral density of $N_0/2$. The optimum receiver computes the correlation metric

$$\ell = \int_0^T \mathbf{r}(t)s(t)dt \quad (2)$$

and compares each specific quantity ℓ with a threshold A and a threshold $-A$. If $\ell > A$, the decision is made that m_1 was broadcasted. If $\ell < -A$ the decision is made in favor of m_3 . If $-A \leq \ell \leq A$, the decision is made in favor of m_2 .

- [3] (a) Determine the three conditional probabilities of error: $P[\text{error}|m_1]$, $P[\text{error}|m_2]$, and $P[\text{error}|m_3]$.
- [2] (b) Determine the average probability of error $P[\text{error}]$ as a function of the threshold A , where the *a priori* probabilities of the three messages are $P[m_1] = P[m_3] = \frac{1}{4}$ and $P[m_2] = \frac{1}{2}$.
- [5] (c) Determine the value of A that minimizes the average probability of error when the *a priori* probabilities of three signals are given as in (b). How does the value of A change if three signals are equally probable? *Hint:* $\frac{\partial Q(x)}{\partial x} = -\frac{1}{\sqrt{2\pi}} \exp\left(-\frac{x^2}{2}\right)$.