

**University of Saskatchewan  
College of Engineering**

**EE 441: Power Systems II  
Final Examination  
A one formula sheet is allowed**

**Instructor: S.O. Faried  
Duration: 3 hours**

**December 7, 2002**

1- Consider the power system shown in Fig. 1. Use a power base of 500 MVA and network reduction to calculate the fault current in Amperes and the line-to-line voltages at the fault point for a sustained single line-to-ground fault at bus D.

$G_1$  : 500 MVA, 13.8 kv,  $x_d'' = 0.2$  p.u.,  $x_2 = 0.2$  p.u. and  $x_o = 0.1$  p.u.

$G_2$  : 600 MVA, 26 kv,  $x_d'' = 0.15$  p.u.,  $x_2 = 0.15$  p.u. and  $x_o = 0.1$  p.u.

$G_3$  : 400 MVA, 13.8 kv,  $x_d'' = 0.2$  p.u.,  $x_2 = 0.2$  p.u. and  $x_o = 0.1$  p.u.

$T_1$  : 500 MVA, 13.8 kv / 500 kv ,  $x = 0.1$  p.u.

$T_2$  : 600 MVA, 26 kv / 500 kv,  $x = 0.1$  p.u.

$T_3$  : 500 MVA, 13.8 kv / 500 kv,  $x = 0.1$  p.u.

Line<sub>AB</sub>,  $x_1 = 50 \Omega$

Line<sub>BC</sub>,  $x_1 = 80 \Omega$

Line<sub>AD</sub>,  $x_1 = 80 \Omega$

Line<sub>BD</sub>,  $x_1 = 120 \Omega$

For transmission lines:  $x_0 = 3x_1$

*Mid term : Solve above using bus admittance matrix. Calculate bus voltage at bus A*

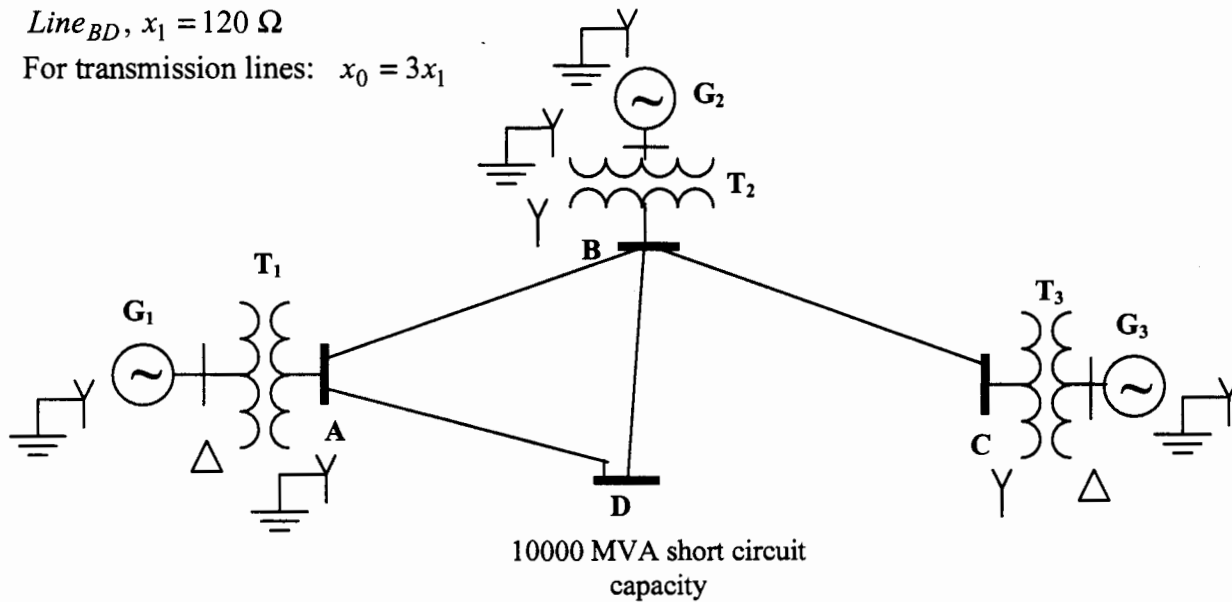

$$x_{1system} = x_{2system}, \quad x_{0system} = 0.5x_{1system}$$

Fig. 1

**(12 Marks)**

2. The data of the sample power system shown in Figure 2 are given in Tables 1 and 2. Using Gauss-Seidel iterative algorithm, perform 2 iterations and check the convergence after each iteration. Use a voltage magnitude tolerance of 0.001, an acceleration factor of 1.6 and 100 MVA base.

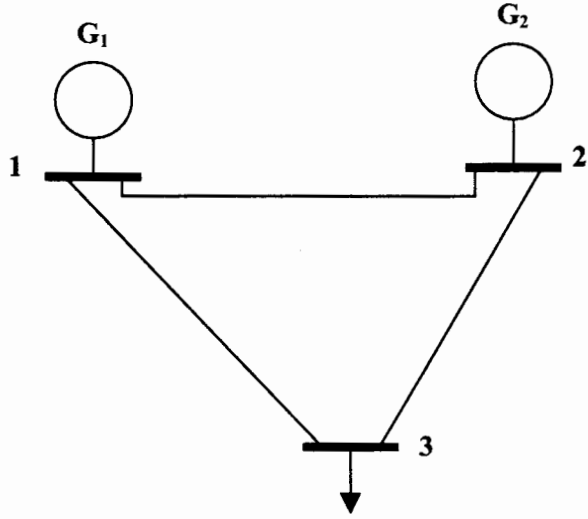

Fig. 2

Table 1: Impedances of the sample power system in p.u. on a 100 MVA base

Bus Code: p - q	Impedance $Z_{pq}$	Line charging $0.5Y_{pq}$
1-2	$0.04 + j0.16$	$j0.15$
1-3	$0.02 + j0.08$	$j0.07$
2-3	$0.05 + j0.12$	$j0.08$

Table 2: Scheduled generation and loads and magnitudes of bus voltages for the sample power system.

Bus code p	Bus voltage	Generation		Load	
		MW	MVAR	MW	MVAR
1	1.04	?	?	0	0
2	1.02	40	?	0	0
3	?	0	0	100	40

(12 Marks)

3. In the system shown in Figure 3, a three-phase fault occurred on one of the transmission lines just after the circuit breaker. Find the following:
- The critical clearing angle in degrees.
  - The critical clearing time in seconds.
  - The generator speed at the instant of clearing in radians per second.

$$x_d' = j0.4 \text{ p.u.}, \quad x_{T.L} = j0.8 \text{ p.u.}, \quad x_{T1} = x_{T2} = j0.1 \text{ p.u.}, \quad M = 7 \text{ sec}$$

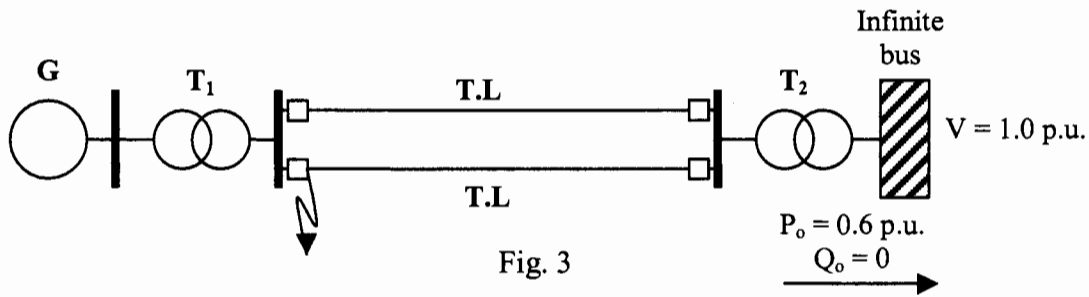

Fig. 3

(12 Marks)

4. In the system shown in Figure 4, a three-phase fault occurred on one of the transmission lines at the middle point. The switch S is opened simultaneously with circuit breakers A and B. Find the critical clearing angle.

$$x_d' = j0.4 \text{ p.u.}, \quad X_C = -j0.1 \text{ p.u.}, \quad x_{T.L} = j1.0 \text{ p.u. (each of the four sections)}$$

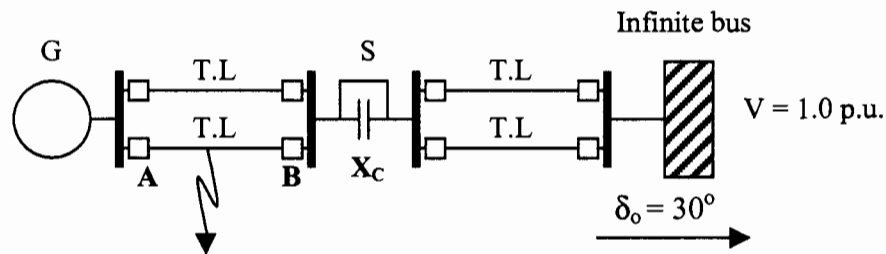

Fig. 4

(12 Marks)

5. Consider the system shown in Figure 5. Using the equal area criterion, discuss whether the transformer neutral reactance  $X_{Tg}$  improves or degrades the system transient stability.

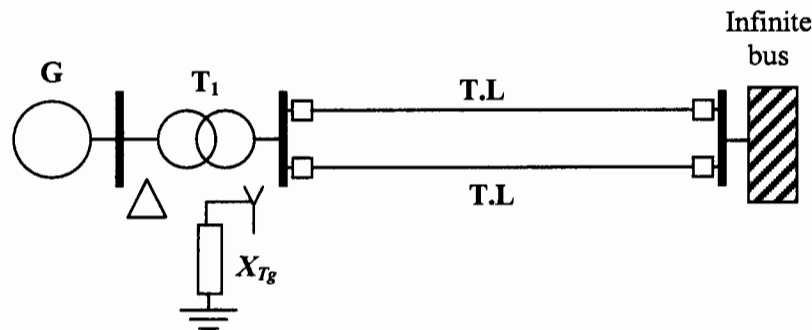

Fig. 5

(6 Marks)

6. Consider the system shown in Figure 6. Find the synchronizing power and the natural frequency of free oscillations.

$$x_d = j1.0 \text{ p.u.}, \quad x_{T.L} = j0.8 \text{ p.u.}, \quad x_{T1} = j0.1 \text{ p.u.}, \quad x_R = j0.5 \text{ p.u.}, \quad M = 7 \text{ sec}$$

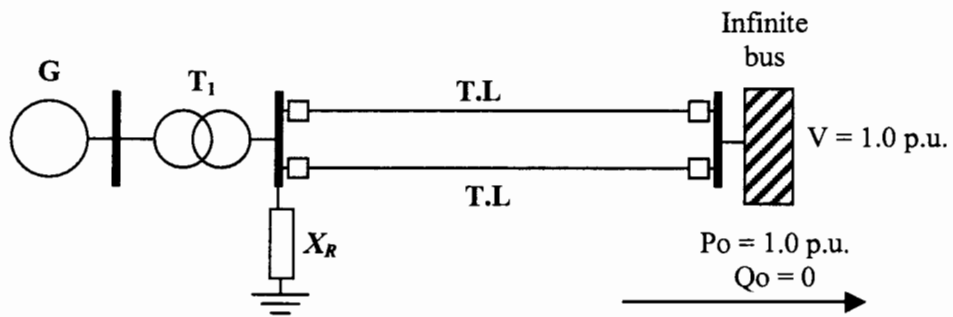

Fig. 6

(6 Marks)