

**University of Saskatchewan
EE 329 Electrical Laboratory III
Midterm Examination**

February 14, 2001

Name: Adam Parker
Student Number: 273376

19/32

**Allowed time: 1 1/2 hours
Closed Book Examination
Answer all questions**

1. Derive the expression for the transfer function $H(s) = e_o/e_i$ for the active filter shown below. Your answer should be in the form $H(s) = \frac{-Ks}{s^2 + \left(\frac{\omega_o}{Q}\right)s + \omega_o^2}$. [5]

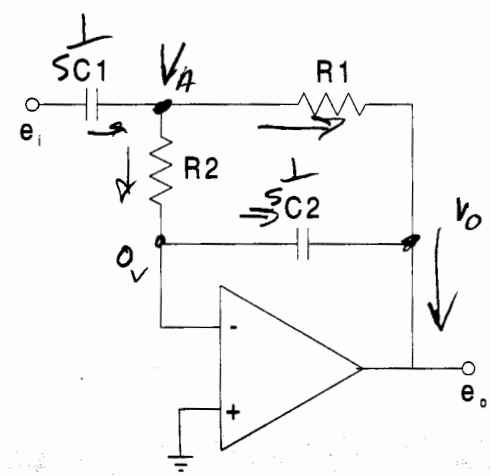

$$(e_i - V_A) \frac{1}{SC_1} + \frac{(V_A - V_o)}{R_1} + \frac{V_A}{R_2} = 0$$

Node A

$$V_A \left(SC_1 + \frac{1}{R_1} + \frac{1}{R_2} \right) = e_i (SC_1) + V_o \left(\frac{1}{R_1} \right) \quad [1]$$

Node V_o

$$V_o \left(SC_2 + \frac{1}{R_1} \right) = V_A \left(\frac{1}{R_1} \right)$$

$$V_o \left(\frac{SR_1C_2 + 1}{R_1} \right) = V_A$$

$$V_A = V_o (SR_1C_2 + 1) \quad [2] \text{ into } [1]$$

$$V_o (SR_1C_2 + 1) \left(\frac{SC_1 R_1 R_2 + R_1 + R_2}{R_1 + R_2} \right) = e_i (SC_1) + V_o \left(\frac{1}{R_1} \right)$$

$$V_o \left(\frac{(SR_1C_2 + 1)(SC_1 R_1 R_2 + R_1 + R_2)}{R_1 + R_2} - \frac{1}{R_1} \right) = e_i SC_1$$

2. A sinusoidal carrier, $c(t) = A_c \cos(\omega_c t)$, and a sinusoidal modulating signal $m(t) = A_m(1 + \mu \cos(\omega_m t))$ are fed into a mixer.

(a) Write an expression for the output signal of the form $s(t) = \text{carrier term} + \text{USB} + \text{LSB}$. [2]

$$A_c \cos(\omega_c t) \cdot A_m (1 + \mu \cos(\omega_m t))$$

$$= A_m A_c \cos(\omega_c t) + A_m A_c \mu \cos \omega_c t \cos \omega_m t$$

$$= A_m A_c \cos(\omega_c t) + \frac{A_m A_c \mu}{2} [\cos(\omega_c + \omega_m)t + \cos(\omega_c - \omega_m)t]$$

(b) If the AD532 – based amplitude modulator circuit you used in the lab is used to mix a carrier, $c(t) = 4.7 \cos(2\pi 19000t)$ V and a modulating signal $m(t) = 2.3(1 + 0.55 \cos(2\pi 2500t))$ V, sketch the output of the circuit as it would appear on (i) an oscilloscope and (ii) a spectrum analyzer. State any assumptions. All aspects of your sketches must be labeled to get full marks for this question. Unlabeled voltages, frequencies, etc. will be very heavily penalized. [4]

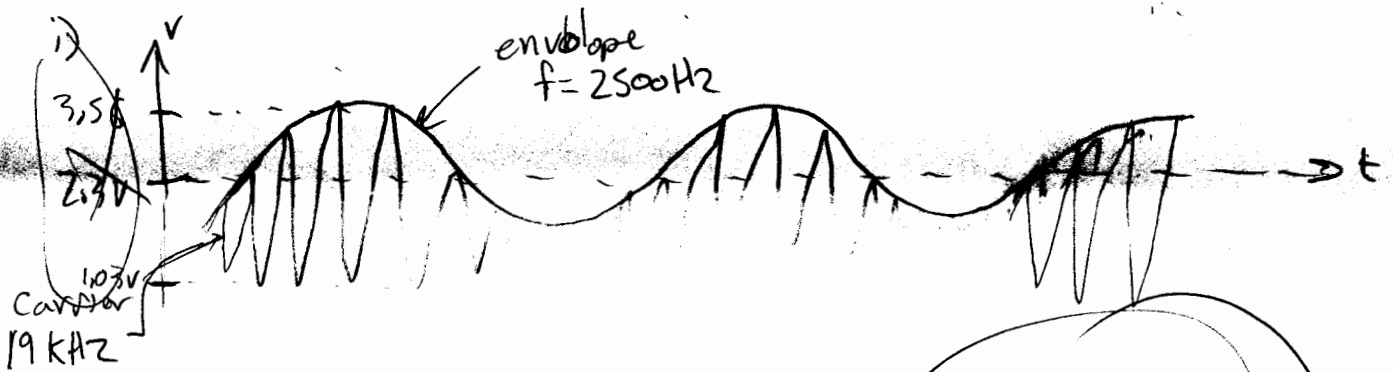

ii)

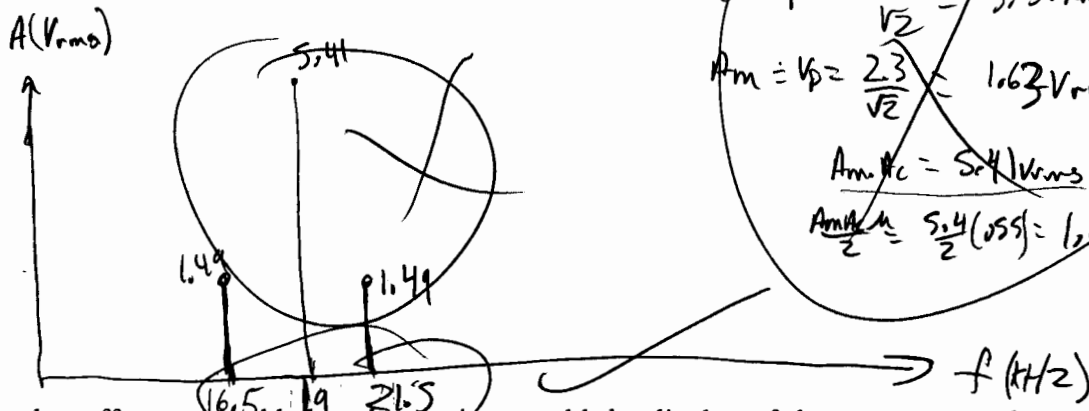

(c) If a d.c. offset were added to the carrier, would the display of the spectrum analyzer be any different from that in (b)? How? [1]

Yes, a frequency at the message frequency, 2500 Hz would appear.

3. A 2 kHz sinusoid is fed into a laboratory PCM module set to 5 bit quantization. The output of the PCM module is fed directly into an HP334A Distortion Analyzer which has been adjusted to measure the SNR of the input signal. The PCM module may accept a $6.25 V_{pp}$ signal without clipping.

(a) What is the theoretical maximum SNR with $N = 5$? [1]

$$\begin{aligned} \text{SNR (dB)} &= 6.02N + 1.77 \\ &\approx 6.02(5) + 1.77 \\ \text{SNR} &= 31.9 \text{ dB} \end{aligned}$$

(b) Fill in the diagram below for $N = 7$ bit quantization, $f_s = 35$ kHz, $f_{BW} = 4.5$ kHz. Assume a 1 kHz sinusoidal input signal. [5]

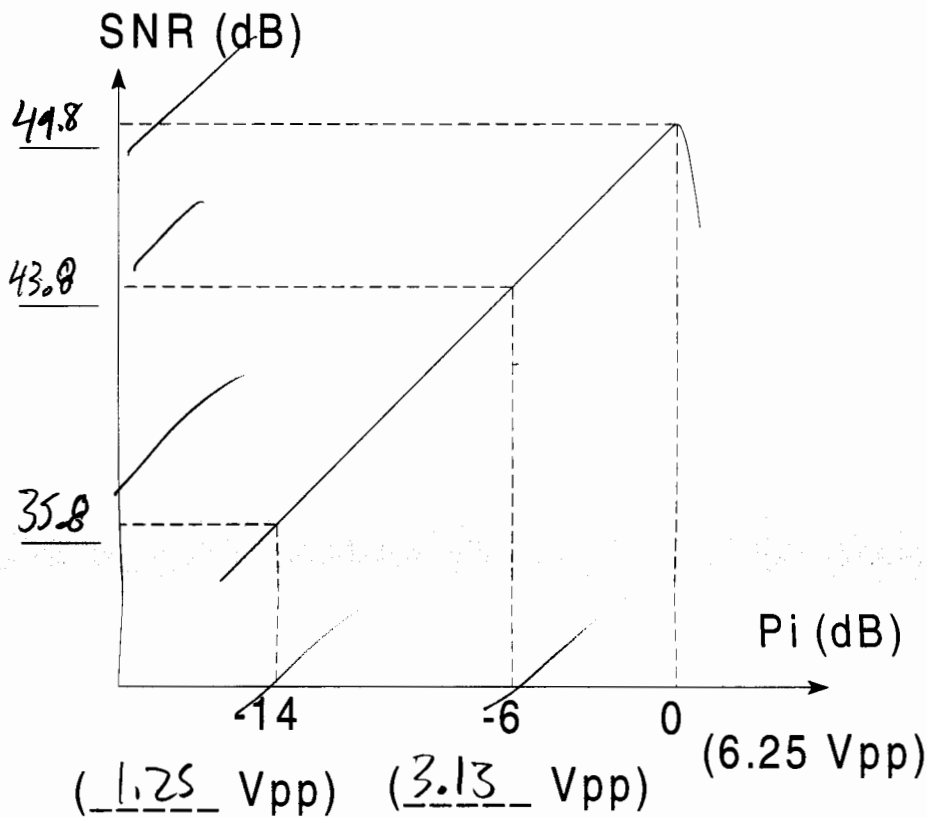

$$\begin{aligned} \text{SNR} &= 6.02N + 1.77 + 10 \log_{10} \left(\frac{f_s/2}{f_{BW}} \right) \\ &= 6.02(7) + 1.77 + 10 \log_{10} \left(\frac{35k/2}{4.5k} \right) \\ &= 49.8 \text{ dB} \end{aligned}$$

Slope is 1 to 1

$$\begin{aligned} \therefore 49.8 - 6 &= 43.8 \text{ dB} \\ 49.8 - 14 &= 35.8 \end{aligned}$$

$$P_{\text{new}} = 20 \log \left(\frac{V_{\text{new}}}{V_{\text{ref}}} \right)$$

$$\begin{aligned} V_{\text{new}} &= V_{\text{ref}} 10^{\frac{P_{\text{new}}}{20}} \\ &= 6.25 \cdot 10^{-14/20} \\ &= 3.13 V_{pp} \end{aligned}$$

$$\begin{aligned} V_{\text{new}} &= 6.25 \cdot 10^{-14/20} \\ &= 1.25 V_{pp} \end{aligned}$$

4. An OPAMP is connected as shown below. When the switch is opened, the output of the OPAMP falls linearly as shown.

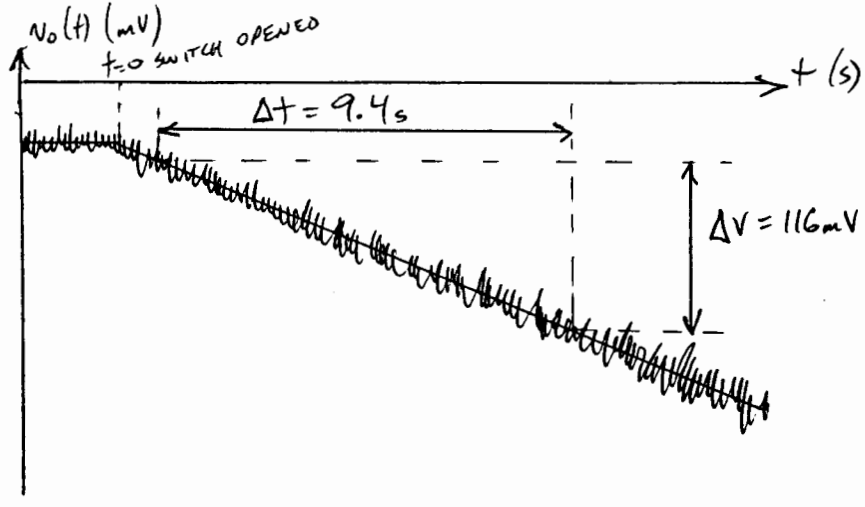
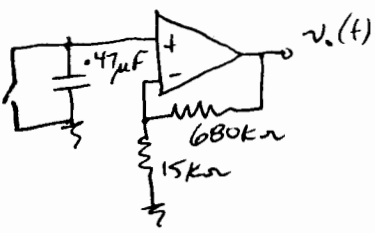

(a) Determine the magnitude and direction of the input bias current.

~~Current out of op AMP.~~

[3]

$$A_v = \frac{680}{15} + 1 = 46.3$$

$$I = C \cdot \left(\frac{\Delta V}{\Delta t} \right) = (0.47 \mu F) \left(\frac{2.5 \text{ mV}}{9.4 \text{ s}} \right)$$

$$I = 119 \text{ pA}$$

$$V_o = 46.3 \cdot V_{cap}$$

$$V_{cap} = \frac{116 \text{ mV}}{46.3} = 2.5 \text{ mV}$$

(b) A differential receiver is shown below. If $R_2/R_3 = R_1/R_F$, then $v_o = (R_F/R_1)(v_2 - v_1)$. If the differential receiver has been optimally adjusted (and it has been), then the CMRR of the receiver will be equal to the CMRR of the OPAMP. Calculate the expected SNR at the output of the receiver if $v_1 = -27 \sin(2\pi 2000t) \text{ mV} + n(t)$ and $v_2 = 27 \sin(2\pi 2000t) \text{ mV} + n(t)$. Here, $n(t)$ is common-mode noise and $n(t) = 2.93 \sin(2\pi 60t) \text{ V}$. Assume that the only significant source of noise in the system is the common-mode noise $n(t)$ and that the CMRR of the OPAMP is 80 dB. [4]

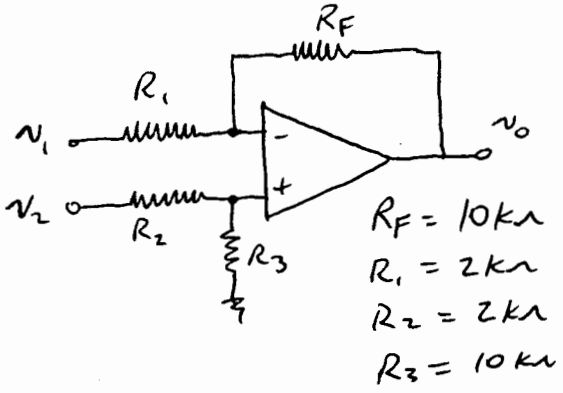

$$v_1 = -27 \sin(2\pi 2000t) \text{ mV} + 2.93 \sin(2\pi 60t) \text{ V}$$

$$v_2 = 27 \sin(2\pi 2000t) \text{ mV} + 2.93 \sin(2\pi 60t) \text{ V}$$

$$10 \frac{80}{20} = \frac{A_{dm}}{A_{cm}}$$

$$A_{cm} = \frac{10}{4}$$

$$A_{cm} = 1 \times 10^{-3}$$

$$CMRR = 80 = 20 \log \left(\frac{A_{dm}}{A_{cm}} \right)$$

2

5. What criteria should be followed when choosing blocking capacitors for BJT amplifiers? i.e. What governs the size (in F) of the blocking caps? [2]

The cap should be only a few ohms for the frequency of the cct, however large enough to appear as high (infinite) to d.c. voltage.

ALL CAPS HAVE $Z(\omega=0) = \infty$, REGARDLESS OF SIZE.

6. You are attempting to observe a single low amplitude, noisy sinusoidal voltage waveform on an oscilloscope and you observe the following jittery, moving waveforms:

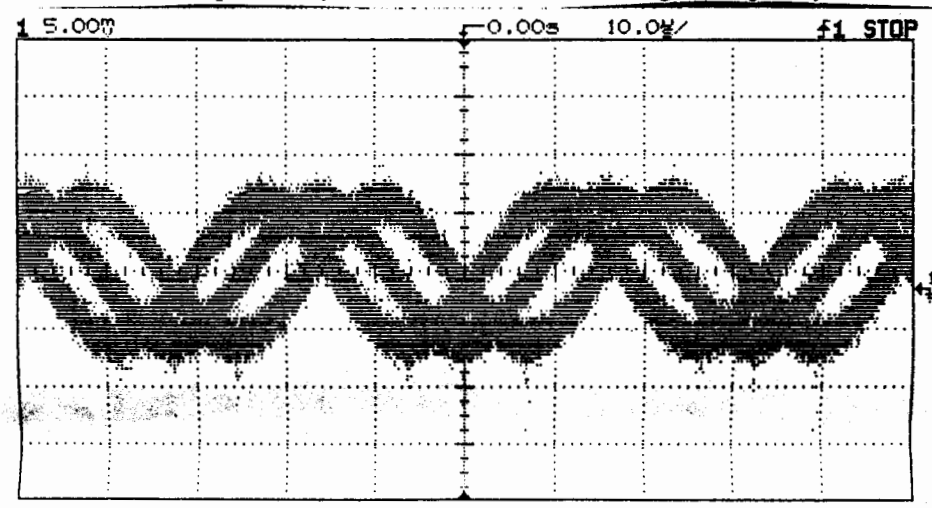

Describe what setting(s) you could adjust or change on the oscilloscope to display a single stable, stationary waveform as shown below: [2]

HINT: It's not averaging.

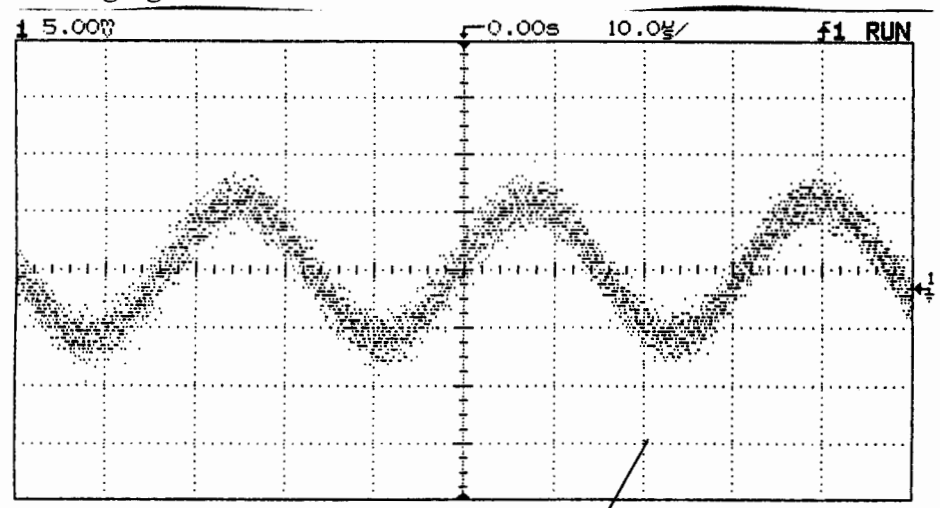

First the trigger should be set to the channel of

7. The input impedance of the common base (CB) amplifier studied in the BJT lab is measured two different ways. Prove that either method yields the same input impedance. Be sure to calculate both the real and imaginary components of Z_{in} .

(a) V, I method:

[3]

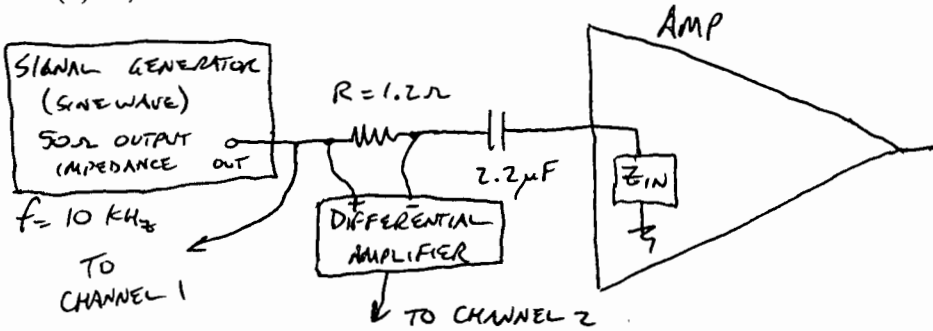

Ch1: 11120 mV
Ch2: 1.58L-7.65 mV

$$i(f) = \frac{1.58L-7.65}{1.2}$$

$$i(L) = 1.32L-7.65mA$$

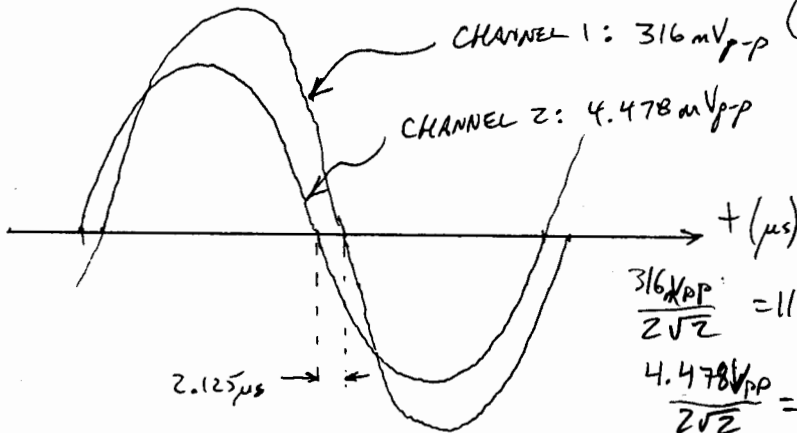

(THE 2 CHANNELS ARE SET TO TWO DIFFERENT V/DIV SETTINGS TO MAKE THEM APPEAR ABOUT THE SAME SIZE)

$$V_c = (1.32L-7.65mA)(-j7.23)$$

$$V_c = 9.54mA-97.7$$

$$V_{ch1} - V_{ch2} - V_c = V_{Zin}$$

$$V_{Zin} = 11120 - 1.58L-7.65 - 9.54L-97.7$$

$$V_{Zin} = 111L4.96mV$$

$$I_i = 1.32L-7.65mA$$

$$Z_{in} = \frac{V_{Zin}}{I_i} = \frac{111L4.96mV}{1.32L-7.65mA}$$

$$T = \frac{1}{f} = \frac{1}{10kHz} = 100 \times 10^{-6}$$

$$\frac{1}{360} = \frac{2.125 \mu s}{100 \mu s}$$

$$\phi = 7.65^\circ \text{ ch1 leads}$$

$$\frac{316 \mu V_{pp}}{2\sqrt{2}} = 111 mV_{rms}$$

$$\frac{4.478 \mu V_{pp}}{2\sqrt{2}} = 1.58 mV_{rms}$$

$$X_c = \frac{1}{\omega C} = \frac{1}{2\pi(10k) \cdot 2.2 \mu F} = 7.23 \Omega$$

$$Z_L = 51.2 - j7.23$$

$$Z_{in} = 84.8L12.6\Omega$$

$$[3] = 82.7L18.5\Omega$$

(b) |V|, adjustable R method:

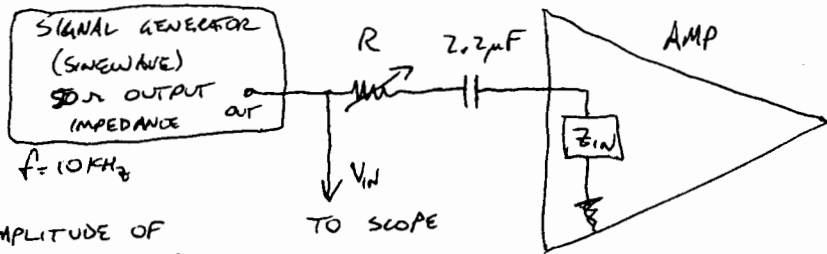

(AMPLITUDE OF SIGNAL GENERATOR WAS CONSTANT FOR BOTH MEASUREMENTS)

R	V _{in}
0 Ω	344.5 mV _{pp} 715.1
42 Ω	357.8 mV _{pp} 358.6

cct 7a

$$12 = j7.23$$

2