

Signature: \_\_\_\_\_

University of Saskatchewan  
Dept. of Electrical Engineering

EE352 Communication Systems I

Instructor: D.E. Dodds

3/4

3/3

Midterm Examination - Friday, Feb. 14, 2003

Seen/4

Time: 2 hours

Total 20 points

4/4

Permitted: Textbook, EE352 Printed Notes, and student's handwritten notes

NOT Permitted - Photocopies of posted solutions or solutions from other students

2 1/2 / 5

Use the space below each question for your answer.

Use the reverse side of the previous page for additional work.

Hand in your entire question paper; do not separate the pages.

12 1/2 / 16

1. a) a speech signal with average power 0 dBm is added to a 60 Hz tone with level -6 dBm.

What is the total resultant power expressed in mW? (1 pt)

Power add on Power Basis

$0\text{dBm} = 10 \log_{10} \left( \frac{P}{1\text{mW}} \right)$   
 $P = 1\text{mW} (10^0)$   
 $= 1\text{mW}$

$\text{Level} = 10 \log_{10} \left( \frac{P}{1\text{mW}} \right)$   
 $-6\text{dBm} = 10 \log_{10} \left( \frac{P}{1\text{mW}} \right)$   
 $\therefore P = 251.19 \mu\text{W}$

$\therefore P = 1.25\text{mW}$  ✓

- b) an audio amplifier has voltage gain of 30. What is the voltage gain in dB? (1 pt)

$\text{Gain (dB)} = 20 \log_{10} (30) = 29.541 \text{ dB}$  ✓

- c) Give the vertical axis units for the three types of spectral illustration. (2 pts)

i) Fourier series

$V$  ✓

ii) Amplitude spectral density.

$V/\sqrt{\text{Hz}}$  ✓

iii) Power spectral density.

~~$W/\sqrt{\text{Hz}}$~~

2. AM transmitters must not exceed 100% modulation otherwise the clipping effect illustrated below may result. When negative modulation voltage is applied, the modulator effectively multiplies by zero. The distorted output waveform has harmonic components that increase the bandwidth of the transmitted signal and cause interference in adjacent radio frequency bands. Illustrate the transmitted spectrum for an extreme case where the transmitted signal resembles that of modulation of a 10 kHz carrier (with amplitude 20 volts) by a half-wave rectified unit amplitude 1 kHz sinusoid. The spectrum of the half-wave sinusoid is reproduced for convenience. (3 points)

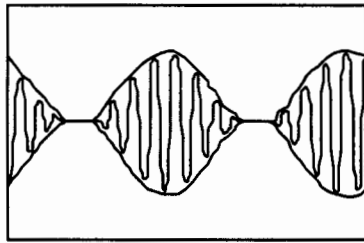

Signal Clipping with Overmodulation

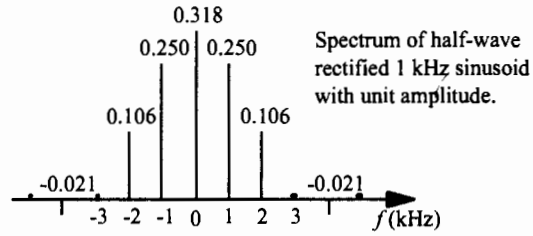

spectrum of

$A_c \cos(2\pi 10k t)$

Volts ✓

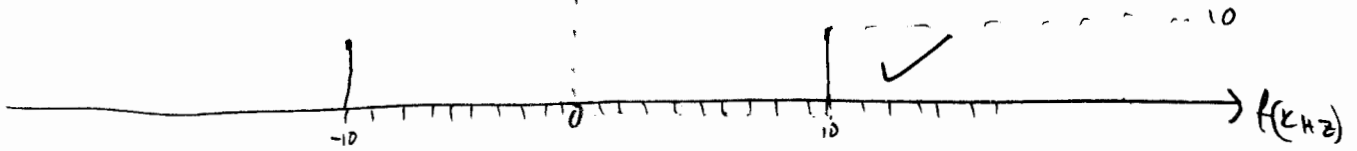

spectrum of modulated signal

Volts ✓

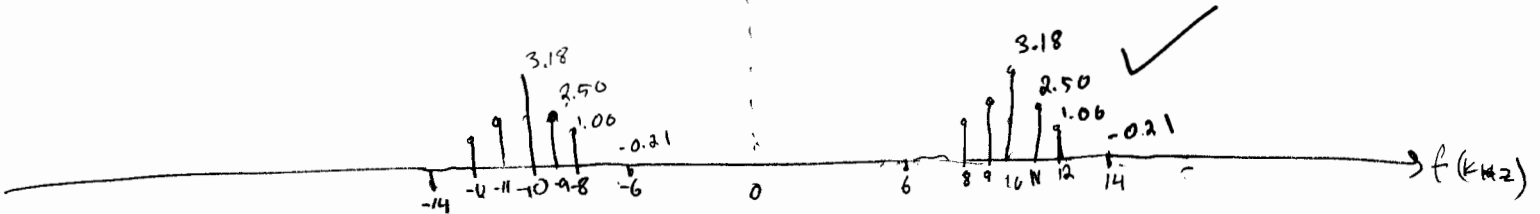

3. Wattmeters can be configured to measure in-phase power (real power) and quadrature power (VARs). Consider the wattmeter circuit below to be a QAM communication system where the in-phase modulating signal is the conductance of the resistor and the quadrature modulating signal is the susceptance of the capacitor. The transmitted signals are read independently on the two wattmeters in the receiver. Relate each element of the "standard" QAM block diagram below to an element or point in the "wattmeter communication system". For example: a) how are the transmitter multipliers implemented? b) how does summation take place in the transmitter? c) where is the 90 degree phase shift in the receiver? d) where are the multipliers in the receiver? and e) where are the lowpass filters in the receiver to remove the double frequency output? (4 points)

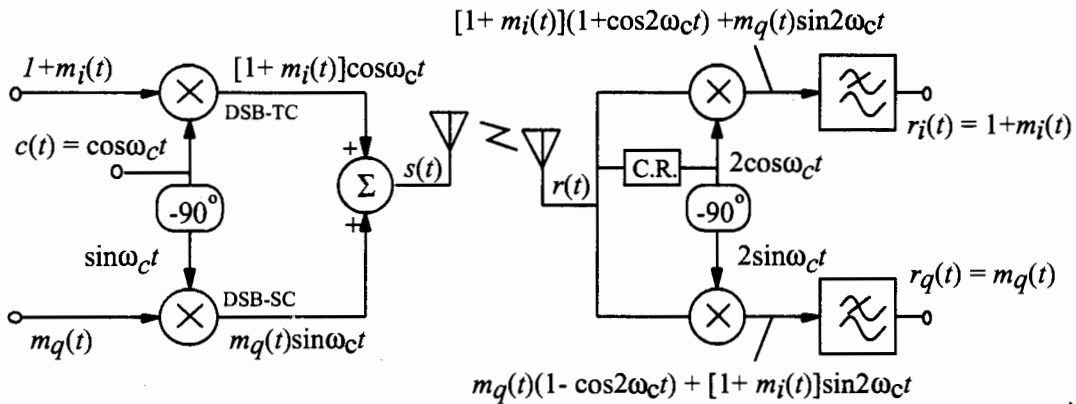
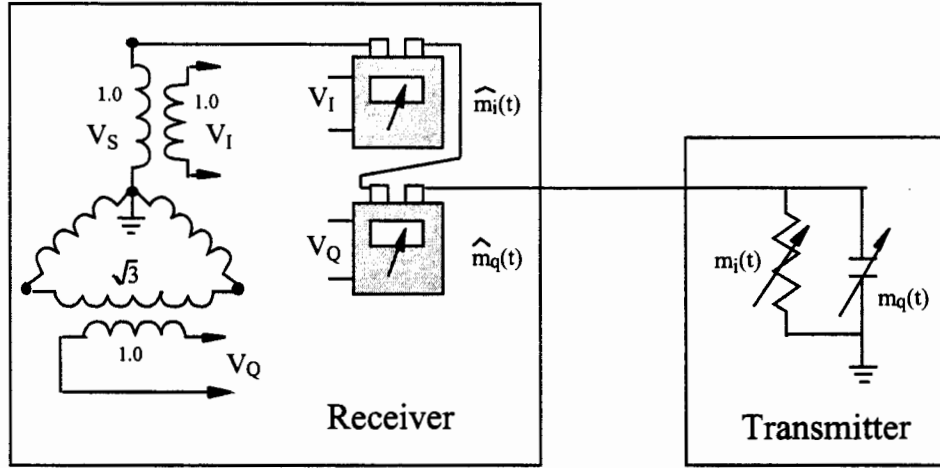

- a) The resistor and capacitor are like the multipliers, by multiplying by their respective values. The capacitor will also give the 90° phase shift with respect to the resistor.
- b) The two signals are then added together by connecting the resistor and capacitor. (this will add the signals) OR the output of the
- c) The 90° phase shift in the receiver comes from the delay between the two wattmeters.
- d) The multipliers of the receiver are the transformers for  $V_I$  and  $V_Q$  (Turns ratio of)
- e) The inductance of the coil will act as a low pass filter removing all high frequency.

4a. Complete the following drill problem. (1 point)

**Drill Problem 3.3 - Phase Modulation** – In the waveforms illustrated in the figure below, assume that the carrier frequency is 1 MHz, the carrier amplitude is 25 volts and the peak modulation voltage is 1.5 volts. Answer the following questions with a precision of 2 decimal places.

a)	Determine $k_p$ , the gain coefficient of phase modulation.	<u>4.19</u> ✓
b)	Determine the phase advance (in radians) when the modulation voltage is +0.75 V.	<u>3.14</u> ✓
c)	What is the modulation frequency (in MHz)?	<u>0.06</u> ✓
Checksum		<u>7.39</u>

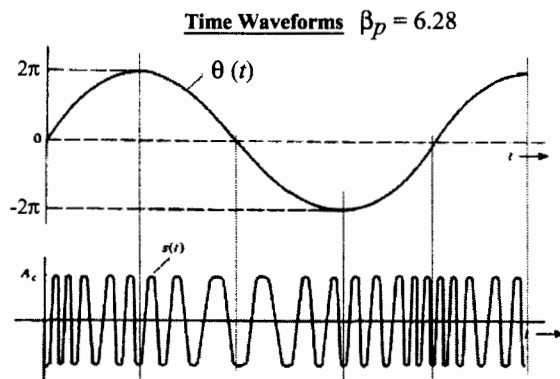

4b. An unmodulated carrier has normalized power equal to 50 watts. (3 points)

- Individually determine the power in the carrier and in the AM sidebands when the carrier is AM-DSB-TC modulated with a 1 kHz sinusoid with modulation index  $\mu = 0.20$ . (watts)
- Determine the total transmitted signal power when the carrier is phase modulated (PM) with a 1 kHz sinusoid with modulation index  $\beta = 0.20$ . (Note that in phase modulation, the transmitted signal amplitude is constant).
- Individually determine the power in the carrier and in the first order (i.e. fundamental) PM sidebands. (It will be useful to recall Parseval's theorem).

a) The power in the carrier does not change.  $\therefore P_c = 50 \text{ W}$  ✓

$$P = (V_{\text{RMS}})^2 \therefore V_{\text{RMS}} = \sqrt{PN} = 7.07 \text{ V}_{\text{RMS}} \therefore A_c = 10 \text{ V}$$

$$P_{\text{USB}} = P_{\text{LSB}} = \frac{(\mu A_c)^2}{2} = 0.5 \text{ W} \quad \checkmark$$

b) Phase modulation is constant power.  $\therefore P_T = 50 \text{ W}$  ✓

c) Because PM is constant power we can calculate the power of the sidebands and subtract it from the total = 50 W to get the carrier power.

With modulation index = 0.2  $\therefore$  the phase modulation is  $\pm 0.2 \text{ rads} = \pm 2 \text{ V}$   
 $\therefore$  sideband amplitude is 1 V

$$\therefore P_{\text{USB}} = P_{\text{LSB}} = \frac{(1 \text{ V})^2}{2} = 0.5 \text{ W} \quad \checkmark$$

$$P_T = P_c + P_{\text{USB}} + P_{\text{LSB}}$$

$$\therefore P_c = 49 \text{ W} \quad \checkmark$$

5. Modern communication receivers use complex signal processing with "analytic" signals. An analytic signal designated  $m^+(t)$  has only positive frequency components and can be expressed as  $m^+(t) = m(t) + j\hat{m}(t)$ . In practical signal processing, two wires or two sample streams are required for each analytic signal

In the "phase shift" method of generating single sideband illustrated below, identify the analytic signals. (1 pt) Discuss how the  $-90$  degree phase shift can be implemented for a sinusoid and for a realistic (wideband) signal such as voice. (2 pts). Expand the block diagram below so that it provides an analytic signal at the output. (2 pts)

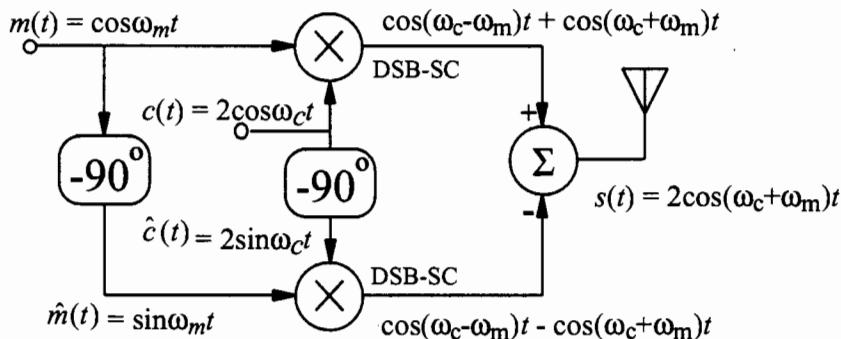

1/2 a) analytic signal  $m^+(t) = m(t) + j\hat{m}(t) = \cos(\omega_m t) + j\sin(\omega_m t)$  ← identify in the diagram.

- b) There are 4 ways to get the  $90^\circ$  phase shift.  
 ① Relay, ② all pass filter ③ Integrator ④ Differentiator  
 - The problem with delay is that you might need a km of delay line to get the  $90^\circ$  at lower frequencies.  
 - The integrator and differentiator are next to useless with frequency and do not work well for realistic signals, but do work for a single sinusoids  
 - The allpass filter is the only one that will work for both the sinusoid and the realistic wideband signal. ← how do you implement?

---

$$2 \sin s \cos t = \sin(s-t) + \sin(s+t)$$

$$2 \cos s \cos t = \cos(s-t) + \cos(s+t)$$

$$2 \sin s \sin t = \cos(s-t) - \cos(s+t)$$

$$\cos(s+t) = \cos s \cos t - \sin s \sin t$$

$$\sin(s+t) = \sin s \cos t + \cos s \sin t$$

---

c)  $2 \sin(\omega_c t) \cos(\omega_m t) = \sin(\omega_c - \omega_m) + \sin(\omega_c + \omega_m)$  END

