

OC Test / SC Test

$$S^2 = P^2 + Q^2$$

$$S = VI^*$$

$$Q = \sqrt{S^2 - P^2}$$

OC: $X_m = \frac{V^2}{Q}$

$R_m = \frac{V^2}{P}$

SC: $X_{eq} = \frac{Q}{I^2}$

$R_{eq} = \frac{P}{I^2}$

$pf = \cos(\theta_{sc}) = \frac{P_{sc}}{V_{sc} I_{sc}} = \frac{P}{S}$

core loss = $P_{oc} = P_e \leftarrow \dots$

copper loss = $P_{sc} = P_{cu} = I^2 R_{eq}$

Max power at $P_c = P_{cu}$

$\eta = \frac{P_{out}}{P_{in}} = \frac{S \cdot pf}{S \cdot pf + P_c + P_{cu}}$

$VR = \frac{V_1 - V_2'}{V_2'}$

$\eta = \frac{n \cdot S \cdot pf}{n \cdot S \cdot pf + n^2 P_{cuFL} + P_{core}}$

$n = \text{load } (0 \rightarrow 1)$

No-load

$R_0 = R_1 + R_m = P_0 / I_0^2$

$Z_0 = V_0 / I_0$

$X_0 = X_{l1} + X_m = \sqrt{Z_0^2 - R_0^2}$

No-load $pf = \cos \phi_0 = P_0 / V_0 I_0$

given $V_L, I_L, P_3\phi$

$\rightarrow V_0, I_0, P_0$

get $\rightarrow Z_0, R_0, X_0, R_m$

PV

$P_{base} = Q_{base} = V_{base} I_{base}$

$Z_{base} = \frac{V_{base}^2}{V_{base} I_{base}}$

$I_{base} = \frac{V_{base}}{Z_{base}}$

$X_{new} = X_{old} \left(\frac{MVA_{new}}{MVA_{old}} \right)^2$

$E_a = K_a \phi \omega_m$

$T_e = K_a \phi I_a$

$P_{em} = E_a I_a = T_e \omega_m$

$\omega_m = \frac{V_t - I_a R_a}{K_a \phi}$

$T_e = \frac{E_a I_a}{\omega_m}$

$T_e = K I_a^2$

$V_t - I_a R_a = K I_a \omega_m$

$V_t = I_a (K \omega_m + R_a)$

DC Machines

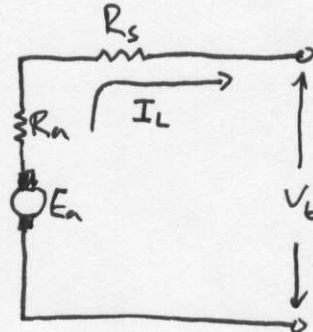
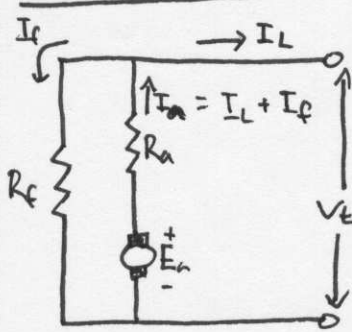

$V_f = I_f R_f, V_t = E_a \pm I_a R_a$ (Motor/Gen)

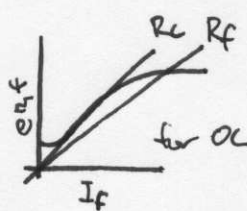

Starting: \rightarrow find E_a for FL

\rightarrow find $K_a \phi$ for FL

$\rightarrow I = \frac{V_t}{R_a + R_{starting}} - \frac{E_a}{K_a \phi}$

$\rightarrow E_a = V_t - (R_a + R_{starting}) I$ (Subst out I)

\rightarrow find new ω_m

Induction Machines

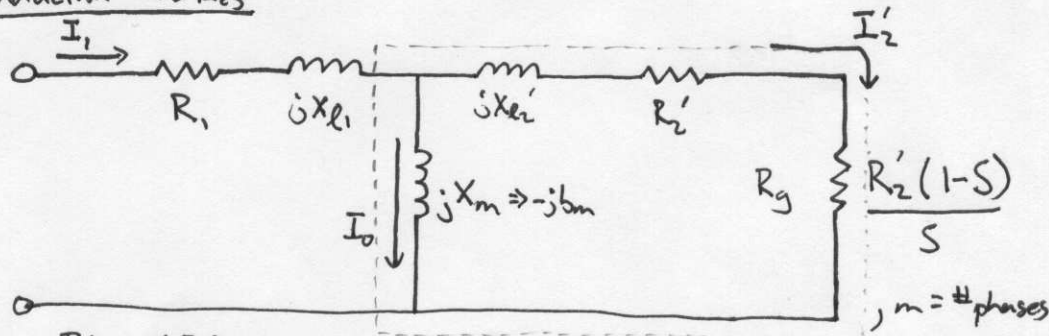

Blocked Rotor

$R_{eq} = R_1 + R_2' = P_s / I_s^2$

$Z_{eq} = V_s / I_s$

$X_{eq} = X_{l1} + X_2' = \sqrt{Z_{eq}^2 - R_{eq}^2}$

Blocked $pf = \cos \phi_s = P_s / V_s I_s$

given $V_L, I_L, P_3\phi$

$\rightarrow V_s, I_s, P_s$

$R_2' = \underbrace{(R_{eq} - R_1)}_{R_2'} \frac{(X_{l2}' + X_m)^2}{X_m^2}$

$X_{l1} = X_{l2}' = X_{eq} / 2$

$X_m = X_0 - X_{l1}$

for motor, $S = 0 \rightarrow 1$

gen, $S = 1 \rightarrow$

$R_f = \text{everything in } \square$

$Z_t = R_1 + jX_{e1} + R_f, \quad \phi = \text{pf}$

$I_1 = V_{in} \phi / Z_t$

only magnitude!
↓
only real!

$P_g = m (I_2')^2 \frac{R_2'}{s} = m I_1^2 R_f$

$P_m = P_g (1-s)$

$P_{rot} = m \left[P_{in} \phi - \underbrace{I_1^2 R_1}_{\text{stator copper loss from NL cond.}} \right]$

$P_{out} = P_m - P_{rot}$

$P_{out} = T_{out} \omega_m, \quad \omega_m = \omega_s (1-s)$

$T_{out} = \frac{P_{out}}{\omega_s (1-s)}, \quad \omega_s = \frac{2\pi f}{\# \text{poles}/2}, \quad T_{out} = \frac{I_2'^2 R_2'}{s \omega_s}, \quad \text{slip at start} = 1$

$P_{in} = \sqrt{3} |V_L| |I_L| (\text{pf})$

$V_{1a} = V_1 - I_0 (R_1 + jX_{e1}) = V_1 \frac{jX_m}{R_1 + j(X_{e1} + X_m)}$
 $R_1'' + jX_1'' = \frac{(R_1 + jX_{e1}) jX_m}{R_1 + j(X_{e1} + X_m)}$
 $S_{maxT} = \frac{R_2'}{\sqrt{(R_1'')^2 + (X_1'' + X_{e2}')^2}}$
 $T_{max} = \frac{1}{\omega_s} \frac{(0.5)m (V_{1a})^2}{\sqrt{(R_1'')^2 + (X_1'' + X_{e2}')^2}}$

$\frac{T}{T_{max}} = \frac{2}{(s/S_{maxT}) + (S_{maxT}/s)}$

$E_{rms} = 4.44 f N \phi, \quad \phi \text{ const?}, \quad E_{rms} \propto f$

slip speed = $\omega_s - \omega_m = s \omega_s$

Swinburn losses test
shunt motor
 $\eta_m = 1 - \frac{V_t (I_f + I_a) + I_a^2 R_a}{V_t (I_f + I_a)}$
 shunt gen
 $\eta_g = 1 - \frac{V_t (I_f + I_a) + I_a^2 R_a}{V_t (I_f + I_a) + I_a^2 R_g}$
 Kapp-Hopkins
generator input = motor output = $\eta (\text{motor input}) = \eta (V_t I_a)$
 generator output = $V I_B = \eta (\text{gen. input}) = \eta^2 V I_a$

$\eta = \sqrt{I_B / I_a}$
 $P = V I_L - (I_a^2 R_{ca} - I_B^2 R_B)$
 $\eta_m = 1 - \frac{P/2 + I_a^2 R_a + V I_a}{V (I_a + I_{ca})}$
 $\eta_g = 1 - \frac{P/2 + I_B^2 R_B + V I_B}{V (I_B - I_{FB}) + P/2 + I_B^2 R_B}$

$I_2' \propto V_1$
 $\frac{I_2' \text{ reduced voltage}}{I_2' \text{ full-load voltage at starting}} = k$

$\therefore I_2' \text{ red voltage} = k (I_2')_{FL} \text{ voltage at starting}$

$V_{X1Z} = V_{Y1Z} \frac{X_{1Z}}{Y_{1Z}}$