

Answer questions 1-5, question 6 is the bonus question.

Open books, open notes.

State clearly your assumptions (if any) in the answers.

Some questions may be more difficult than the others, time yourself.

**1. Question 1 (10 marks)**

Derive the formulae to calculate resistant  $R_g$  of a sensor in the bridge measurement without taking line resistances  $R_L$  into account in Figure (a) and with  $R_L$  in Figure (b).

The formulas should be a function of  $V_i$ ,  $V_o$ ,  $R_3$ , and  $R_L$ .

For  $V_i=6V$ ,  $R_g=200\Omega$ ,  $R_L=1\Omega$ , what is the error if  $R_L$  is not included in the calculation?

$R_3 = 100\Omega$

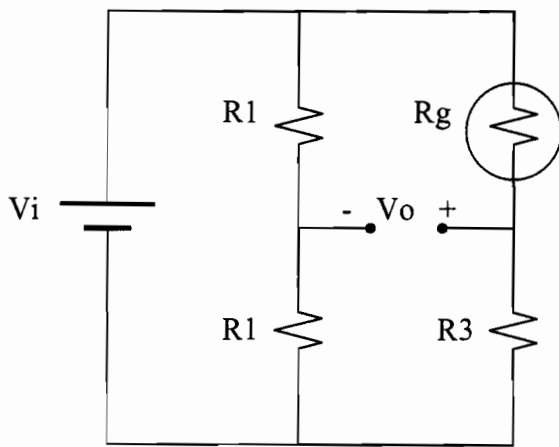

(a)

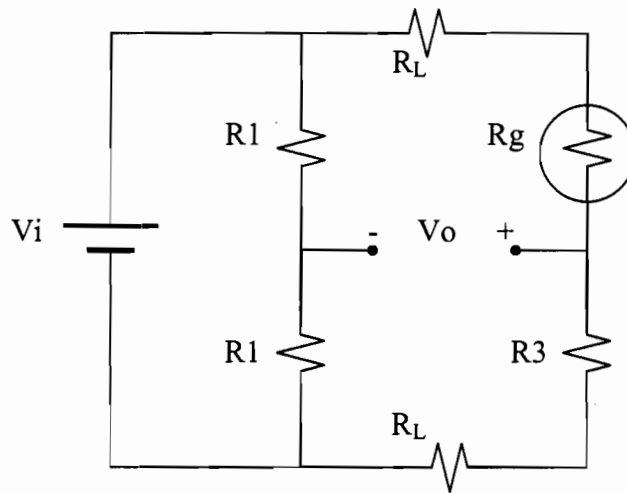

(b)

**2. Question 2 (10 marks)**

A researcher is interested in measuring several parameters in an animal housing facility (a pig barn). These parameters include the temperature and airflow at ten locations throughout the barn and the overall ventilation rate (that is, the rate at which ventilating fans are removing air from the inside of the barn). In addition, the humidity of the exhaust air is to be measured.

The measurements are to be stored in a computer for later analysis. The researcher expects that measurements need not be taken as frequently as once per minute, but they should be taken more often than once every ten minutes. An accuracy of 5% is acceptable, but 1% is desirable.

Give a functional block diagram of an instrumentation system that could perform these functions. Describe the transducers that would be most feasible, giving your reasons for those choices. In general terms describe the interfacing required for each of the transducers that you have selected. Also, give the constraints on the analog to digital conversion process used to acquire the measurements.

### 3. Question 3 (10 marks)

A resistor  $R_{shunt}$  is used to linearized the thermistor  $R_t$  of the circuit in Figure (a) below (this circuit is in page 181 of your note). The shunt resistor is determined to be  $4,960\Omega$  as in the example to cover a temperature range from  $0$  to  $70^\circ\text{C}$ . Response of the thermistor after linearization is shown in Figure (b). The output of the op-amp is required from  $0\text{V}$ - $10\text{V}$  for the range of temperature to be useful. Design a transducer using this circuit and provide all necessary information leading to the selection of component values ( $R_1$  to  $R_6$ ) including the reference voltages.

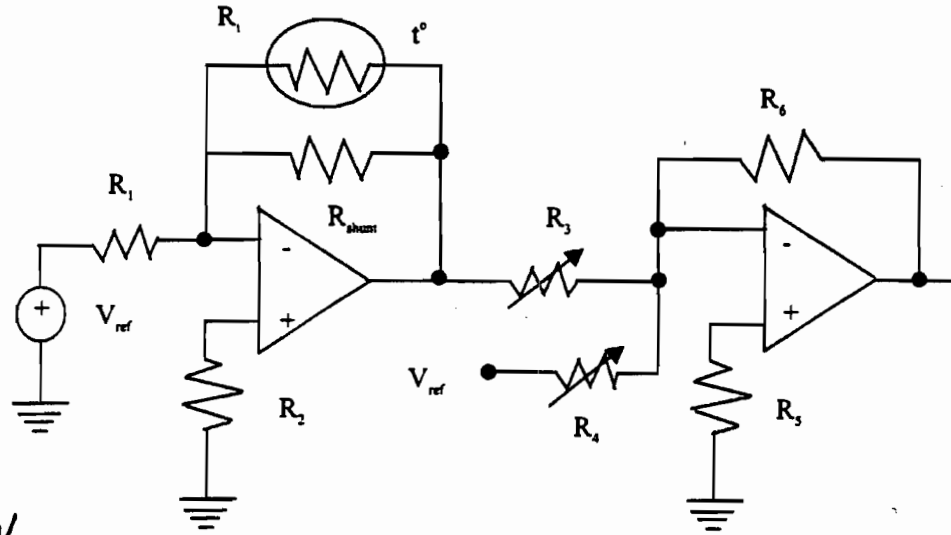
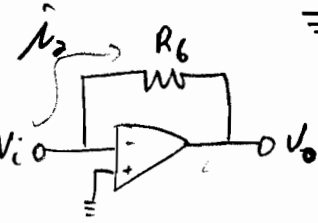

Figure (a)



$$\frac{(V_i - V_o)}{R_6} = i_2$$

### THERMISTOR LINEARIZATION NETWORK DEVIATION VERSUS TEMPERATURE

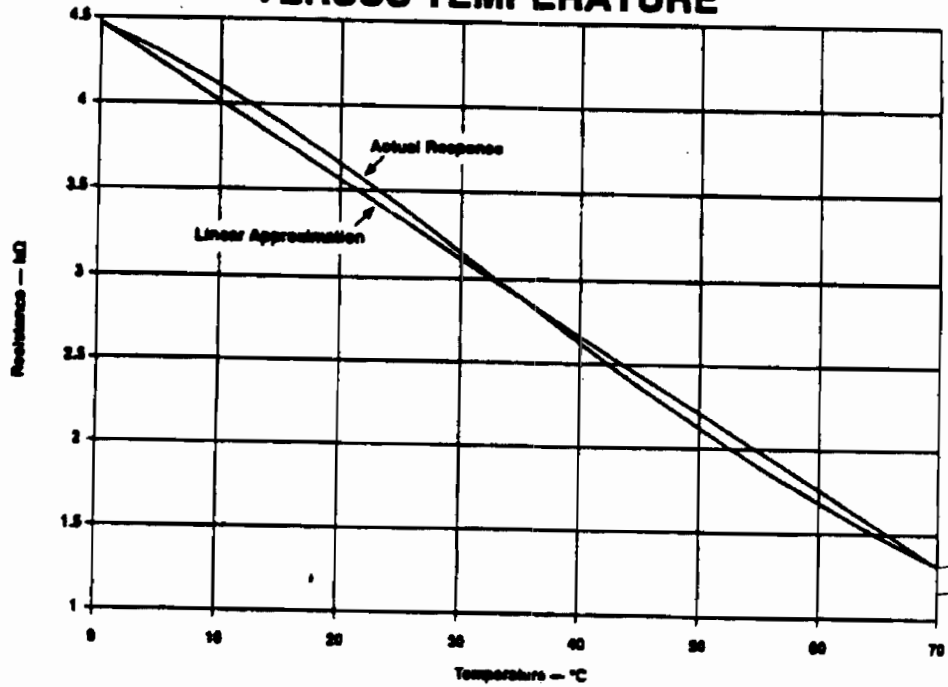
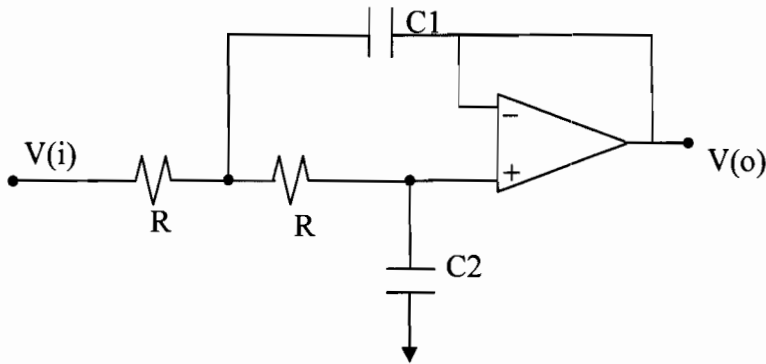

Figure (b)

4. Question 4 (10 marks)



(a) For the above circuit, assume the op-amp is ideal, derive a transfer function  $V_o/V_i$  in the form of

$$T(s) = \frac{V(o)}{V(i)} = \frac{N(s)}{s^2 + \frac{\omega_0}{Q}s + \omega_0^2} . \text{ What filter function does this circuit perform?}$$

- (b) Using the transfer function obtained from (a), design a filter with  $\omega_0=10\text{Krad/s}$  and  $Q = \frac{1}{\sqrt{2}}$ . Only  $10\text{K}\Omega$  resistors are available.
- (c) How much  $\omega_0$  and bandwidth of the filter will change if the actual resistances are 10% below  $10\text{K}$ ?

5. Question 5 (10 marks)

The figure below is one of a class circuits that was described by Sallen and Key. Let  $K = \frac{V2}{V1} = 1 + \frac{Rb}{Ra}$  be the gain of the non-inverting amplifier.

- a. Using normalized values  $R1=R2=1$  and  $C1=C2=1$ , apply KCL at nodes **a** and **b** (or any other analyzing technique) to find the transfer function in the form of  $T(s) = \frac{V2}{V1} = \frac{K\omega_0^2}{s^2 + \frac{\omega_0}{Q}s + \omega_0^2}$ .
- b. What is the relationship between  $Q$  of the filter and amplifier gain  $K$ ?
- c. Re-draw the circuit with the normalized values ( $R1=R2=1$ ,  $C1=C2=1$ ,  $Q = \frac{1}{\sqrt{2}}$ ,  $Ra=?$ ,  $Rb=?$ ).
- d. Scale the resistors  $R1=R2=10\text{K}$  for a frequency of  $10\text{KHz}$ . What are  $C1$ ,  $C2$ ,  $Ra$ ,  $Rb$ ?

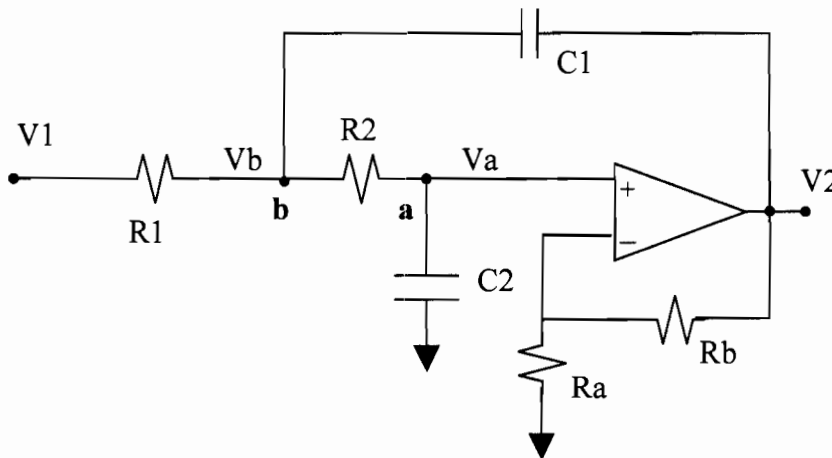

Handwritten notes:

$$2 - 2s + s + s^2$$

$$2 - s + s^2$$

6. Question 6 (bonus 5 marks)

Derive the transfer function,  $V_o/V_{in}$ , of the all-pass filter below. For a given  $R$ ,  $L$ ,  $C$ , find frequencies at which the output undergoes a phase shift of  $90^\circ$  (i.e., frequencies are functions of  $R$ ,  $L$ ,  $C$ ). Find sensitivity of the  $90^\circ$  frequency with respect to the capacitor  $C$ .

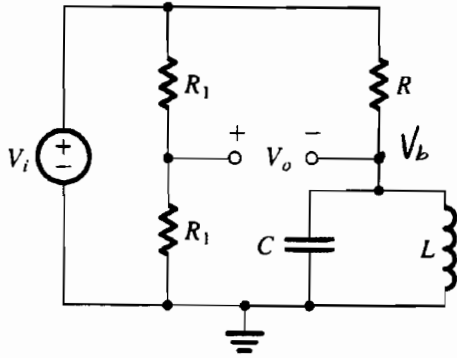

$$\frac{-b \pm \sqrt{b^2 - 4ac}}{2a}$$