

Instructor: **A. Dinh**

Room: **2C82**

Time: **45 minutes**

Note: Return this booklet to Room 2C82 upon completing

Student Name: _____

Student #: _____

Question 1: A technician sets up a circuit with two CD74AD10 (triple 3-input NAND gate) chips and obtains the waveform show below using a logic analyzer. A, B, C are the inputs and Z is the output. Show his connection by drawing the lines connecting the inputs and the output to the two CD74AD10 and the inter-connections between the chips.

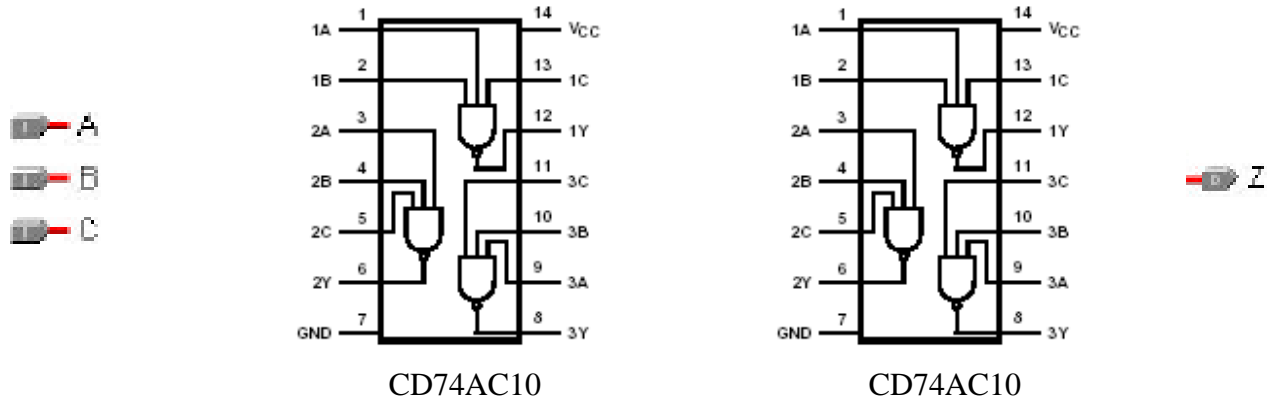
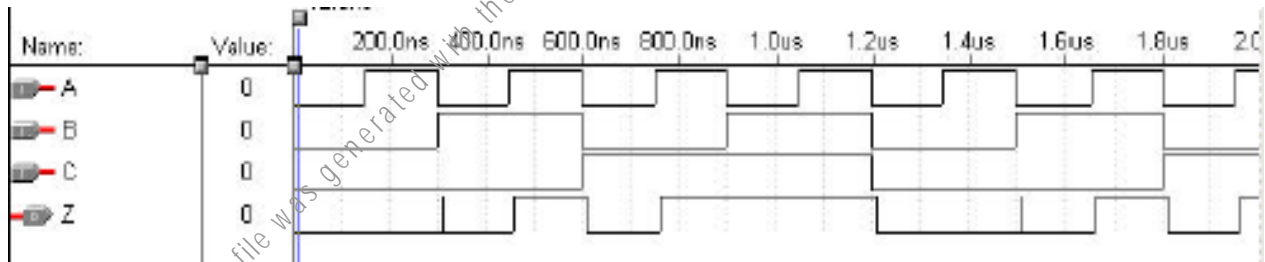

Question 2: Show the connection of a **74HC151 MUX** used to implement the following Boolean function

$$Z(A,B,C) = AB+BC+AC$$

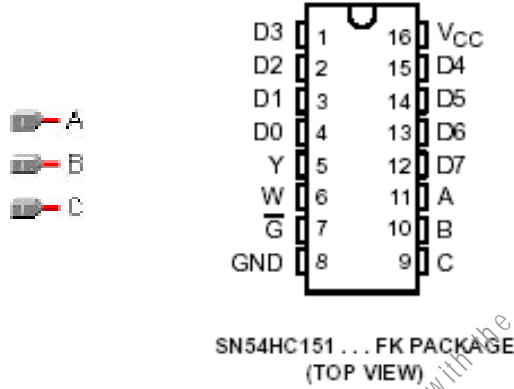

FUNCTION TABLE

INPUTS			STROBE \overline{G}	OUTPUTS	
C	B	A		Y	W
X	X	X	H	L	H
L	L	L	L	D0	$\overline{D0}$
L	L	H	L	D1	$\overline{D1}$
L	H	L	L	D2	$\overline{D2}$
L	H	H	L	D3	$\overline{D3}$
H	L	L	L	D4	$\overline{D4}$
H	L	H	L	D5	$\overline{D5}$
H	H	L	L	D6	$\overline{D6}$
H	H	H	L	D7	$\overline{D7}$

D0, D1 ... D7 = the level of the respective D input

Question 3: (Time allowed 12 minutes)

For this question, the circuit has been set-up (mark the set-up number in your paper). Pin 1 of the 7493 3-bit counter is connected to a 1kHz, 2.5V_{0-P} square wave. Using the provided logic analyzer or oscilloscope, display the waveforms on pin 5, 9, 10 and 11 of the 74LS151. From the waveforms, determine its input word (D₀ to D₇).

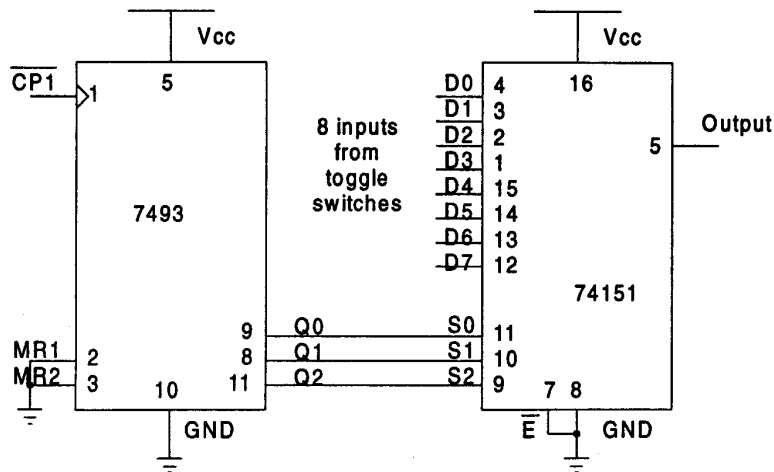

Set-up #: _____

D ₀	D ₁	D ₂	D ₃	D ₄	D ₅	D ₆	D ₇

Instructor: M. Fotuhi-Firuzabad

Student Name: _____

Room: 2C70

Student #: _____

Note: Return this booklet to Room 2C70 upon completion

Q1. Three identical impedances can be connected either as a three-phase delta or as a three-phase wye load. For a given balanced three-phase supply, the power dissipation in the delta configuration will be _____ times that of the power dissipation in the Y configuration.

- (a) 3 (b) $\sqrt{3}$ (c) 1/3 (d) $1/\sqrt{3}$

Q2. The power factor angle of a balanced three-phase load is the angle between its:

- (a) Line current and the line voltage
 (b) Phase current and the corresponding line voltage
 (c) Phase current and the corresponding phase voltage.

Q3. Mark true (T) or false (F):

- (a) The two-wattmeter method cannot be used to measure the total power in an unbalanced 3-phase load.
 (b) The current in the neutral wire of a balanced Y-to-Y connection is zero.
 (c) The algebraic sum of the three phase voltages in a balanced, sinusoidal 3-phase system is zero.

Q4. What should the wattmeters read in the following circuits?

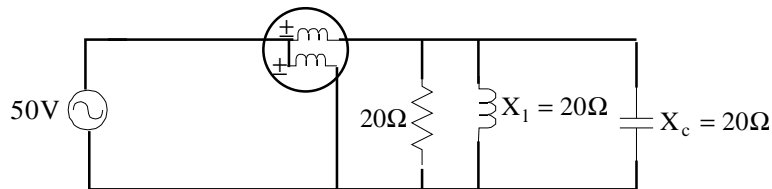

P= _____

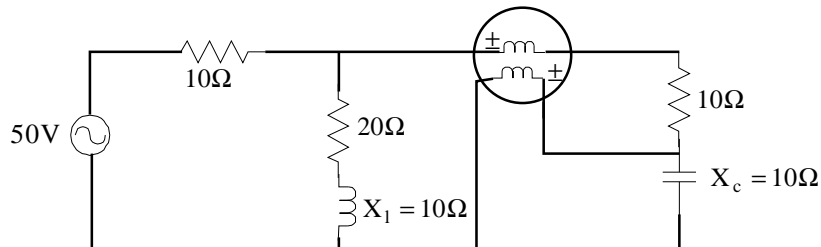

P= _____

EE292.2

Final Examination

Date: April 04, 2002

Instructor: M. Fotuhi-Firuzabad

Student Name: _____

Room: 2C70

Student #: _____

Note: Return this booklet to Room 2C70 upon completing

Q5. The circuit shown below has been set-up. In this circuit, $R1=32\Omega$ and $C1=80\mu\text{F}$.

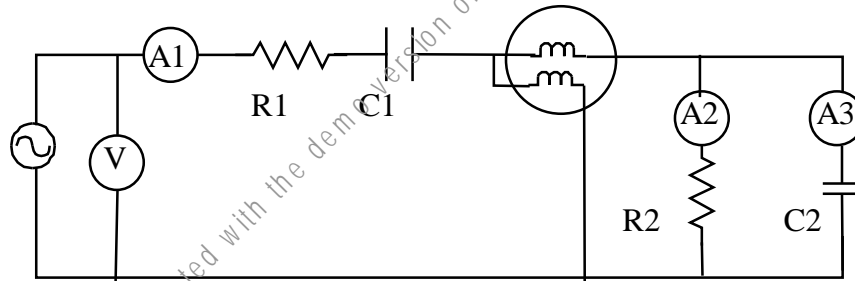

Using readings from the meters, determine:

- Total active power in Watts.
- $R2$ and $C2$.
- Total reactive power.
- Power factor of the circuit.

Instructor: A. S. Mehr

Room: 2C72

Time: 45 minutes

Note: Return this booklet to Room 2C72 upon completion

Student Name: _____

Student #: _____

Question 1: (4 points)

In the following figure, the ammeter has the reading of 11.2(A). Find the resistance of the load (R).

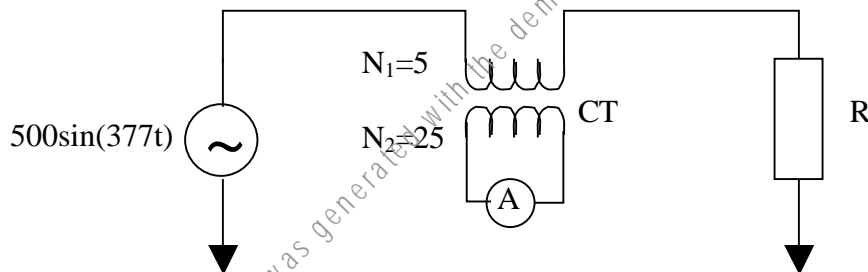
**Question 2:** (14 points)

A 1.5KVA, 110V, 60Hz single-phase transformer gave the following test results:

- i. Open-circuit test, low potential winding excited
 $V_{OC} = 110V$, $I_{OC} = 0.4A$, $P_{OC} = 25W$, $V_{HP} = 220V$
 - ii. Short-circuit test, low potential winding excited
 $V_{SC} = 8.25V$, $I_{SC} = 13.6A$, $P_{SC} = 40W$
 - iii. Direct-current winding resistances
 $R_{LP} = 0.113$, $R_{HP} = 0.413\Omega$
- a. Determine the equivalent circuit of the transformer referred to the low potential.
 - b. Determine the full-load efficiency when the transformer is supplying at 110V, a load circuit with a lagging power factor of 0.8.

Question 3: (7 points)

An RLC circuit with the following schematic is provided in the box. Connect this circuit to a (1.1V, 2.0 KHz) power supply. Find the output voltage.

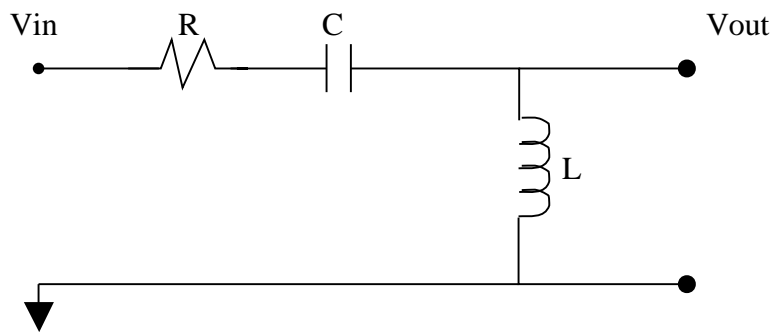

EE292.2

Final Examination

Date: April 04, 2002

Instructor: D. Lynch

Room: 2C80

Time: 45 minutes

Note: Return this booklet to Room 2C80 upon completion

Student Name: _____

Student #: _____

1) (Time allowed: 15 minutes)

Determine 'n' for the unknown diode connected in the circuit (similar to that shown at right).

Recall that: $I \approx I_S e^{\frac{qV}{nkT}}$

n = _____

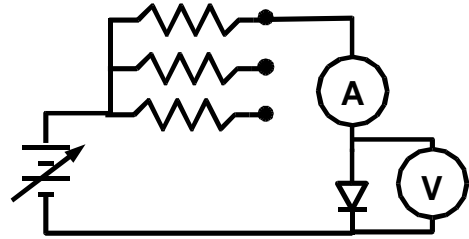

This file was generated with the demo version of the PDF Compressor printer driver

2) (Time allowed: 15 minutes)

a) Design and draw the schematic for a diode – resistor circuit that will give an output approximately as shown when connected to a $10V_{0-P}$ sinusoidal input waveform. (Assume ideal diodes – i.e. a forward biased voltage drop of approximately 0V)

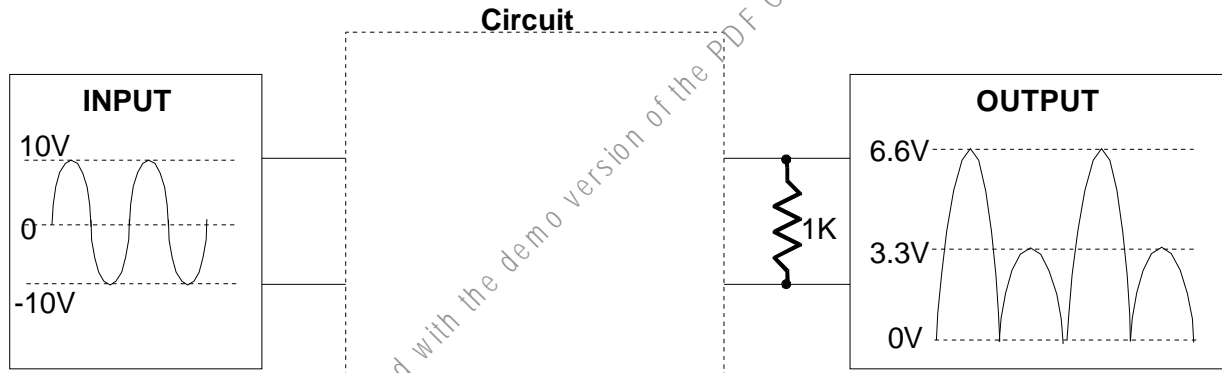

b) Determine a value of R in the schematic shown at right that will bias the circuit such that $e_o = 4.5V_{DC}$ when the input is not connected.

R = _____

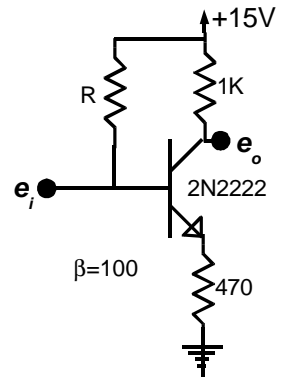

3) (Time allowed: 15 minutes)

Use the setup provided (approximately as shown at right) to determine β_{AC} for the transistor in question.

$\beta_{AC} =$ _____

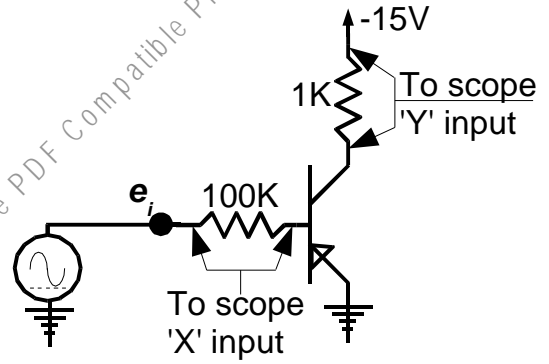

This file was generated with the demo version of the PDF Compatible Printer Driver