

EE 221 Midterm Solutions

October 30, 2002

1)

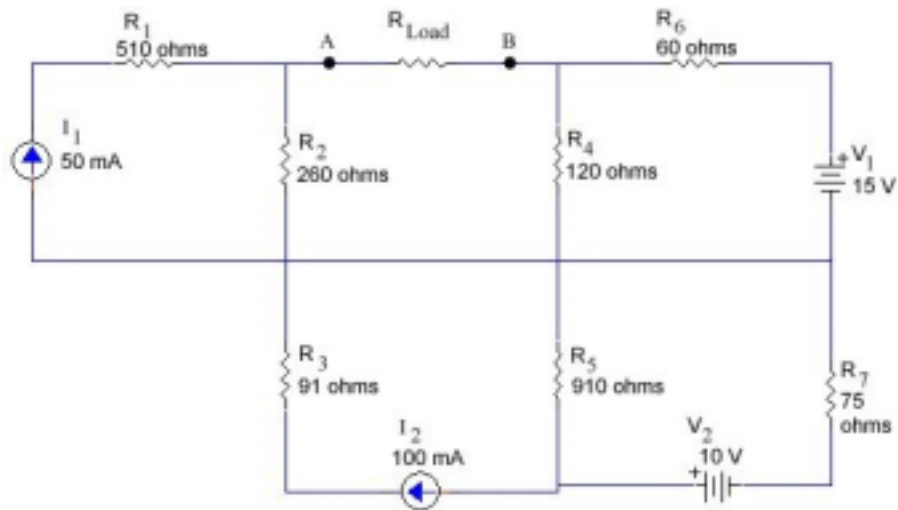
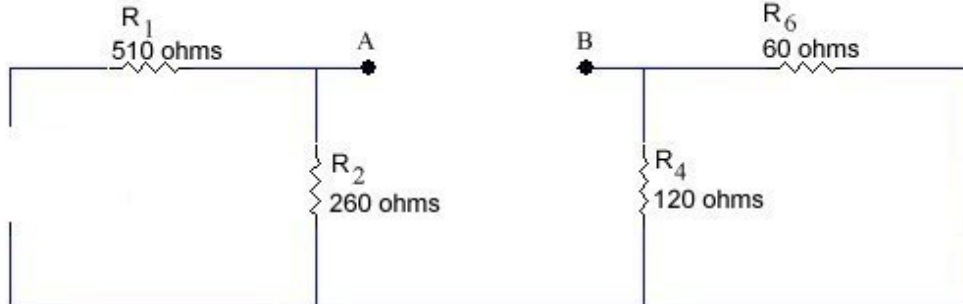

Figure 1

a) Determine and sketch the Thevenin's equivalent circuit for the output terminals A and B.

Solution

First one should realize that R_3 , R_5 , and R_7 along with I_2 and V_2 have no bearing on the final solution. Thus the circuit to determine R_{TH} is:



$$R_{TH} = R_2 + R_4 // R_6 = 300 \Omega$$

Circuit to determine V_{TH} is:

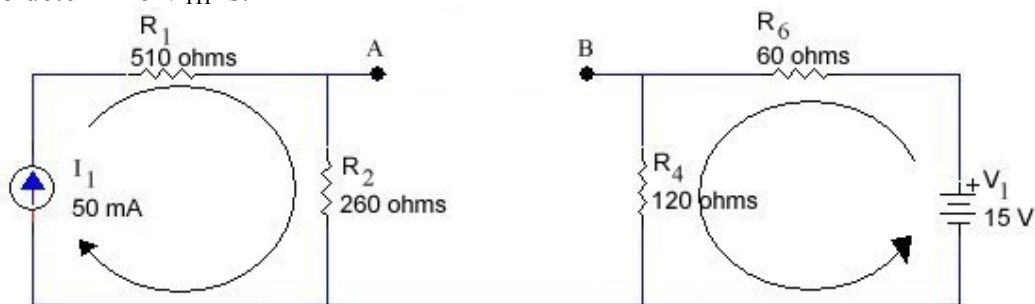

$$V_A = I_1 \times R_2 = 50 \text{ mA} \times 260 \Omega = 13 \text{ V} \quad \text{and} \quad V_B = V_1 \frac{R_4}{R_4 + R_6} = 15 \text{ V} \frac{120 \Omega}{120 \Omega + 60 \Omega} = 10 \text{ V}$$

EE 221 Midterm Solutions

October 30, 2002

$$V_{AB} = V_{TH} = V_A - V_B = 13 \text{ V} - 10 \text{ V} = 3 \text{ V}$$

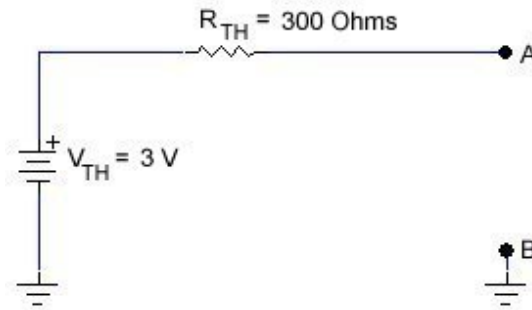

Thevenin Equivalent Circuit.

b) At what value of load resistance will $600 \mu\text{A}$ flow through the load?

$$600 \mu\text{A} = \frac{V_{TH}}{R_{TH} + R_{Load}} \therefore R_{Load} = \frac{V_{TH}}{600 \mu\text{A}} - R_{TH} = \frac{3\text{V}}{600 \mu\text{A}} - 300 \Omega = 4.7 \text{ k}\Omega$$

c) At what value of load resistance is maximum power transferred?

$$R_{Load} = \underline{300 \Omega}$$

Maximum Power is transferred when $R_{Load} = R_{TH} = 300 \Omega$

d) What would be the minimum load resistance if this Thevenin's equivalent circuit was to be a stiff voltage supply?

$$R_{Load(\min)} = \underline{30 \text{ k}\Omega}$$

From the definition of a stiff supply! $R_{Load(\min)} = 100 \times R_S$. In this case R_S is the Thevenin resistance (R_{TH}). Hence $R_{Load(\min)} = 100 \times 300 \Omega = 30 \text{ k}\Omega$

e) What is the Norton's equivalent circuit?

(Provide a circuit sketch as well)

$$R_N = R_{TH} = 300 \Omega \quad \text{and} \quad I_N = \frac{V_{TH}}{R_{TH}} = \frac{3\text{V}}{300 \Omega} = 10 \text{ mA}$$

Norton Equivalent Circuit.

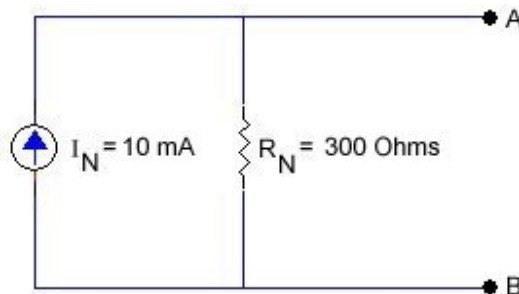

EE 221 Midterm Solutions

October 30, 2002

2) (Use the second approximation of the diode!)

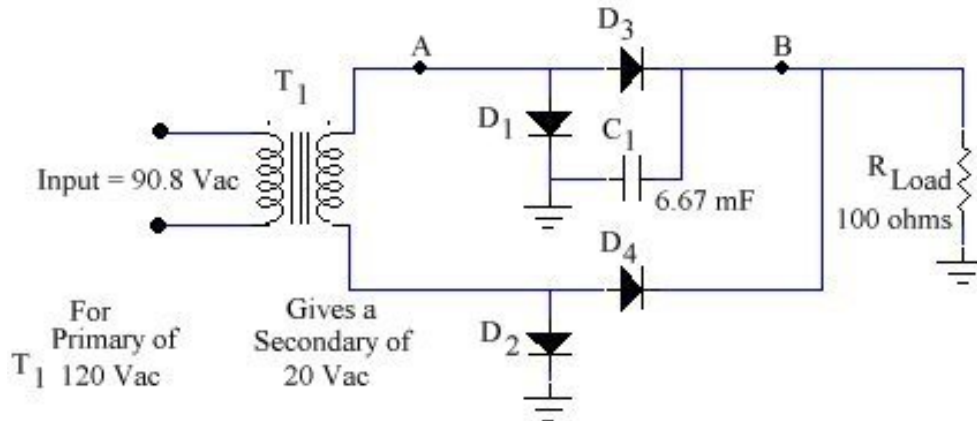

Figure 2

NOTE: There is an error on the diagram, both D₁ and D₂ should be flipped so that the anode is connected to ground. With the above configuration the output would be zero as there is no ground connection for current flow.

a) What is the peak or maximum voltage across the load?

$$V_{Load} = \underline{20 V}$$

For a primary transformer voltage of 120 Vac gives a secondary voltage of 20 Vac means that the transformer turns ratio is, $\frac{120Vac}{20Vac} = 6$. Thus for a primary voltage of 90.8 Vac the secondary voltage is $\frac{90.8Vac}{6} = 15.133Vac = 15.133Vac \times \sqrt{2} \cong 21.4V_p$

Realizing that this is a bridge rectifier and the fact that we are using the second approximation of the diode gives a load voltage of $21.4 V - 1.4 V = 20 V$.

b) What is the peak to peak ripple voltage at the load?

$$V_{ripple} = \underline{0.250 V_{P-P}}$$

$I_{Load(max)} = \frac{V_{Load}}{R_{Load}} = 0.2A$ and since this is a bridge rectifier circuit as well means that the rectified frequency is double the input frequency of 60 Hz. Hence the time between charging for the capacitor is $\frac{1}{120Hz} = 8.3msec$

So to find the change in charge is as follows; $\Delta Q = 0.2A \times 8.3msec = 1.6mC$

$$Capacitance = \frac{\Delta Q}{\Delta V} \therefore \Delta V = \frac{\Delta Q}{C} = \frac{1.6mC}{6.67mF} = 249.9mV_{P-P} \cong 0.250V_{P-P}$$

EE 221 Midterm Solutions

October 30, 2002

c) What rectifier configuration is this supply? **Bridge Rectifier (well supposed to be 🤖)**

d) Using the graph on the next page, sketch the waveform at point 'A'. Also on the same graph sketch the resulting waveform at point 'B' both with and without the capacitor in circuit.

(You must indicate which waveform is which along with voltage levels.)

Please try to be neat! A sloppy diagram may lead to a misinterpretation and lost marks.

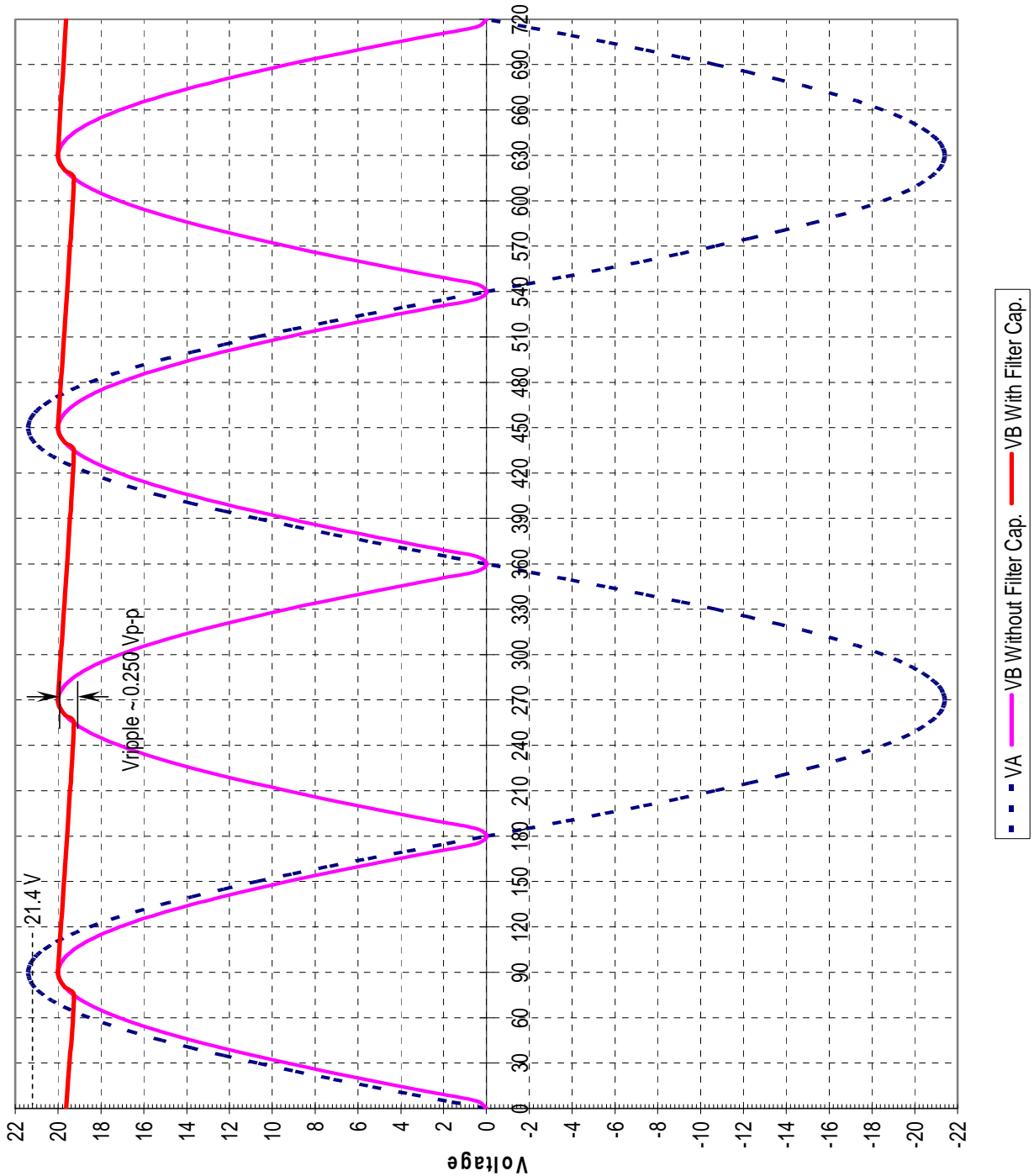

EE 221 Midterm Solutions

October 30, 2002

- 3) **(Use the second approximation of the diode!)**
Sketch the waveform at each terminal, A, B, C, and D on the supplied graphs.

Please try to be neat! A sloppy diagram may lead to a misinterpretation and lost marks.

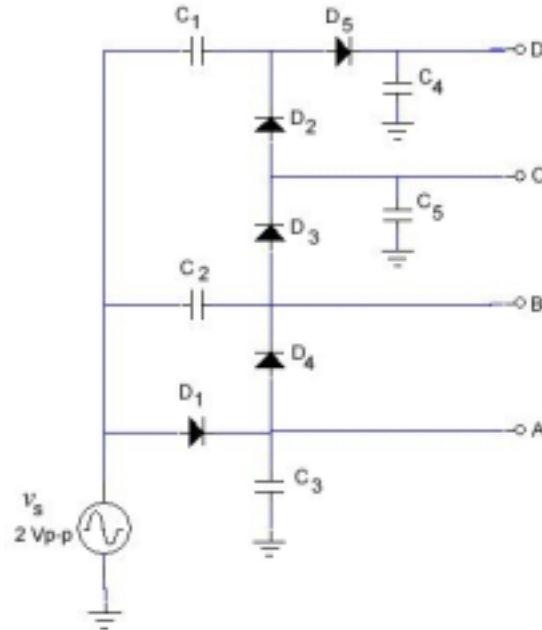

Figure 3

Circuit break down:

D_1 and C_3 = Peak Detector 1. Sets up a bias for Clamper 1.

C_2 and D_4 = Clamper 1.

D_3 and C_5 = Peak Detector 2. Sets up a bias for Clamper 2.

C_1 and D_2 = Clamper 2.

D_5 and C_4 = Peak Detector 3.

EE 221 Midterm Solutions

October 30, 2002

Question 3 Continued

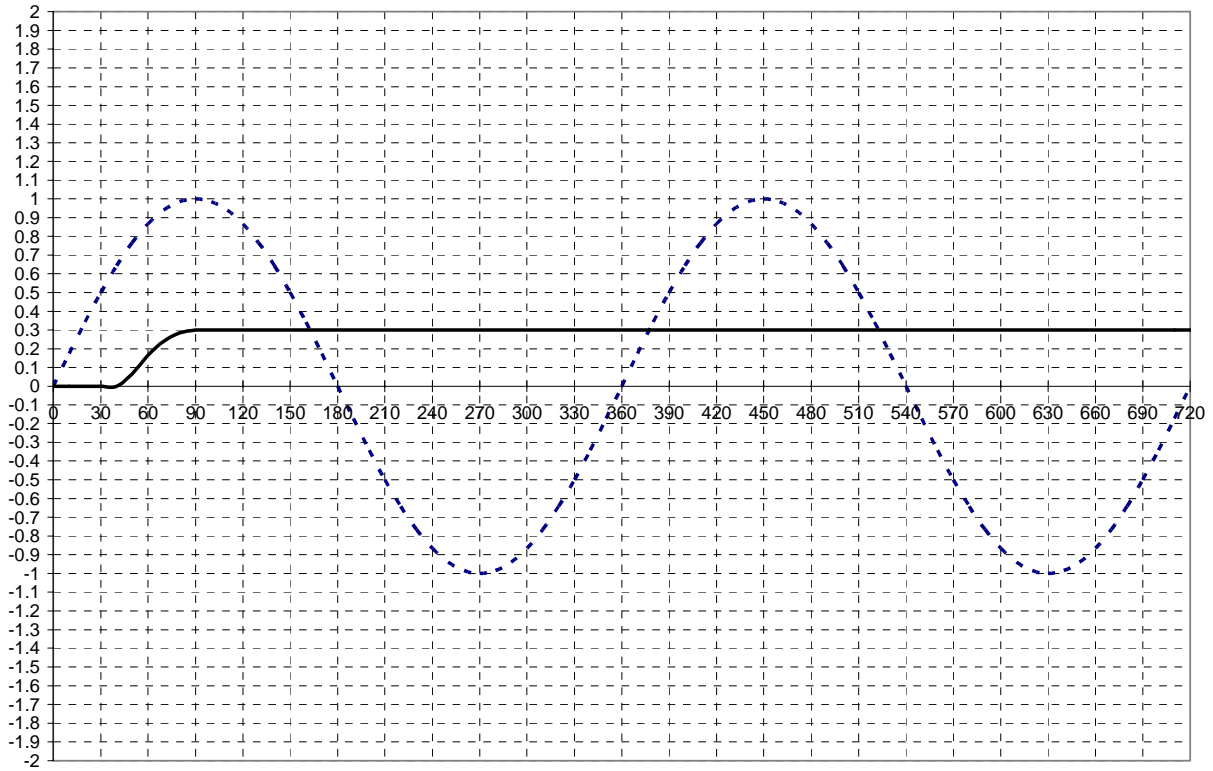

Graph 1 for V_A

--- V_s — V_A

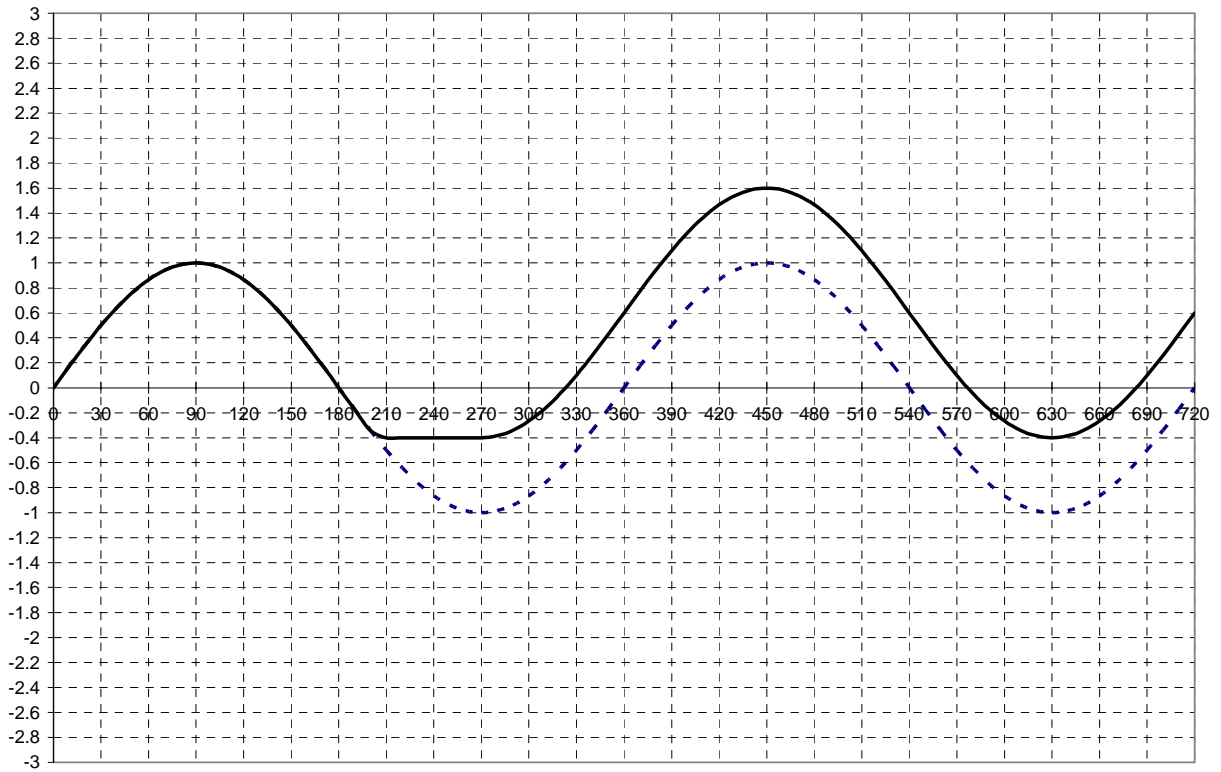

Graph 2 for V_B

--- V_s — V_B

EE 221 Midterm Solutions

October 30, 2002

Question 3 Continued

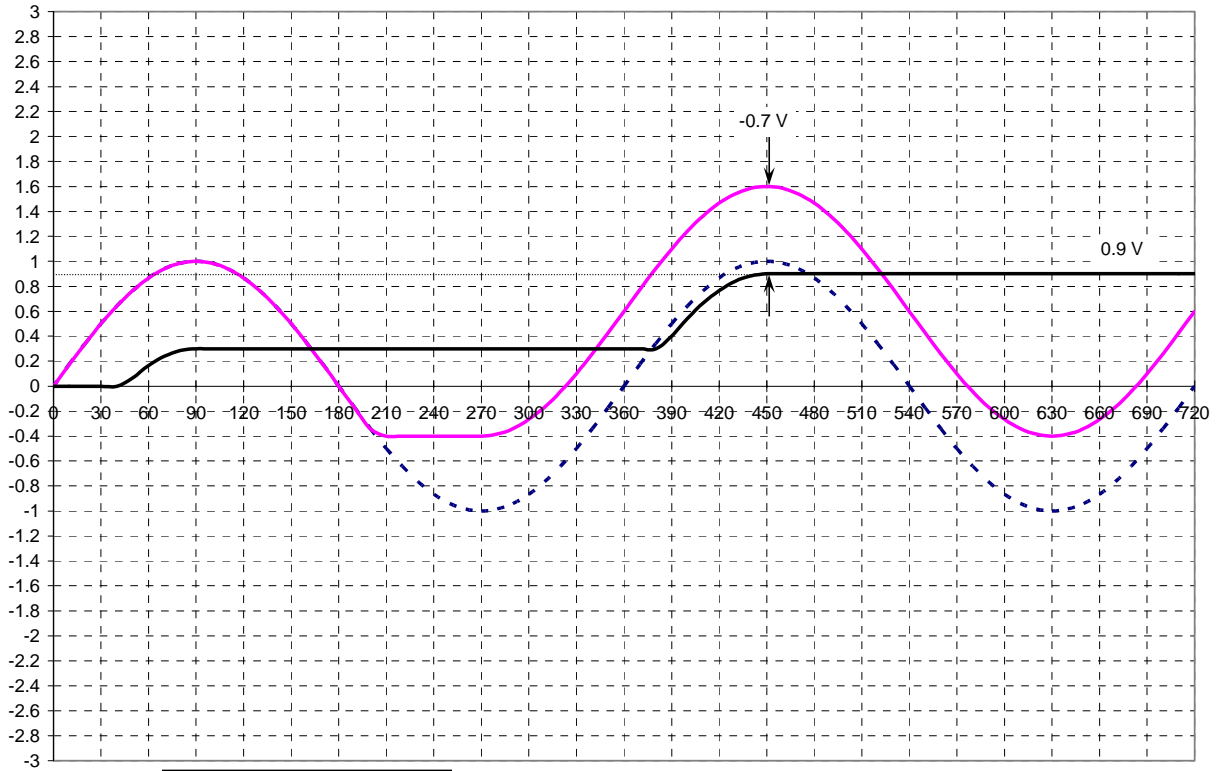

Graph 3 for V_C

- - - V_s — V_B — V_C

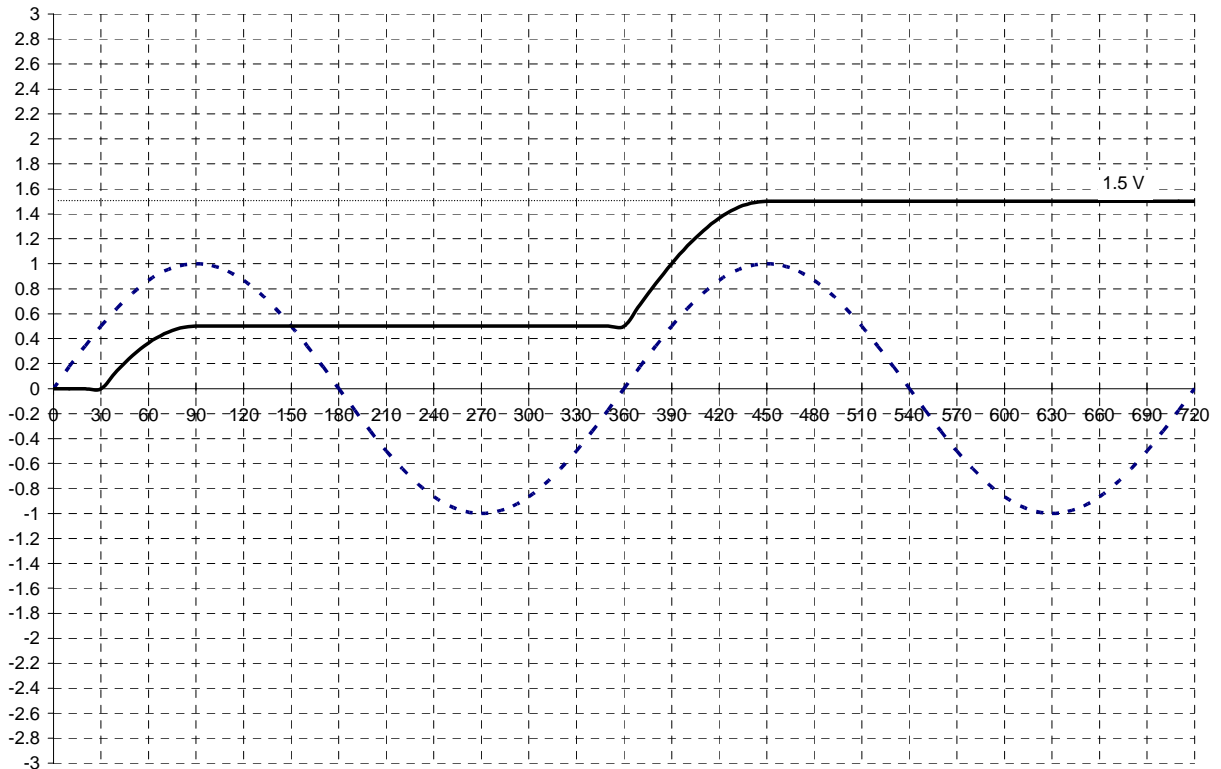

Graph 4 for V_D

- - - V_s — V_D

EE 221 Midterm Solutions

October 30, 2002

- 4) (Use the second approximation of the diode!)
 With the given V_{in} sketch V_{out} on the same graph.

Please try to be neat! A sloppy diagram may lead to a misinterpretation and lost marks.

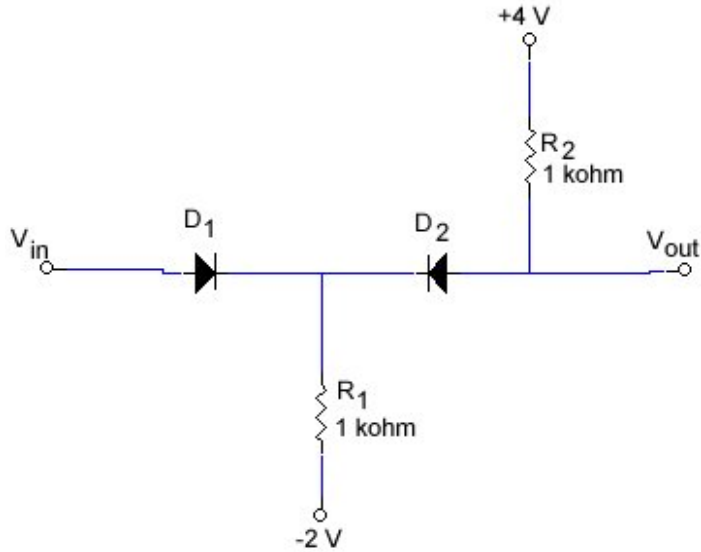

Because there are supplies attached means that the diodes will have a forward biased region for an input waveform. To determine what this region is and how the output will look is as follows. First let's determine a relationship between V_{in} and V_{out} . This can be done by choosing an intermediate point such as V_1 .

$$V_{out} = V_1 + 0.7 \text{ V and } V_1 = V_{in} - 0.7 \text{ V}$$

$$\rightarrow V_{out} = V_{in} - 0.7 \text{ V} + 0.7 \text{ V}$$

But this is not for all cases of V_{in} ! The upper end will be limited by the +4 V supply. In other words for an input signal greater than 4 V D_2 will be reversed biased. To determine the lower limit we have to find what V_1 is when no input signal is applied. In this condition current will flow from the +4 V supply through R_2 , D_2 and R_1 to the -2 V supply.

Figure 4

$$I = \frac{4V - 0.7V - (-2V)}{R_1 + R_2} = 2.65 \text{ mA}$$

$$V_1 = IR_1 - 2V = 0.65V$$

But we are interested in $V_{out} = V_1 + 0.7 \text{ V} = 1.35 \text{ V}$ therefore the lower limit is 1.35 V.

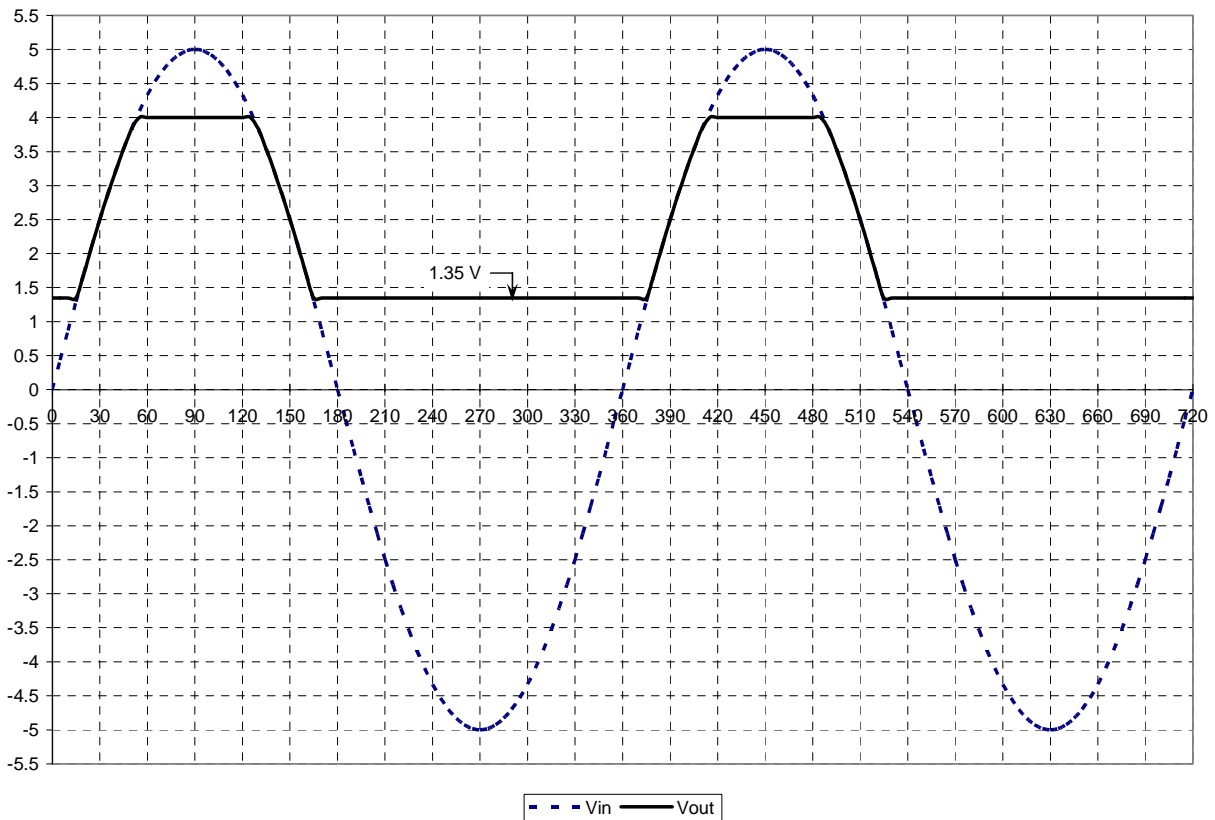

EE 221 Midterm Solutions

October 30, 2002

5) (Assume $\beta = 100$, $V_{BE} = 0.7\text{ V}$ and $V_{CE(sat)} = 0.3\text{ V}$)

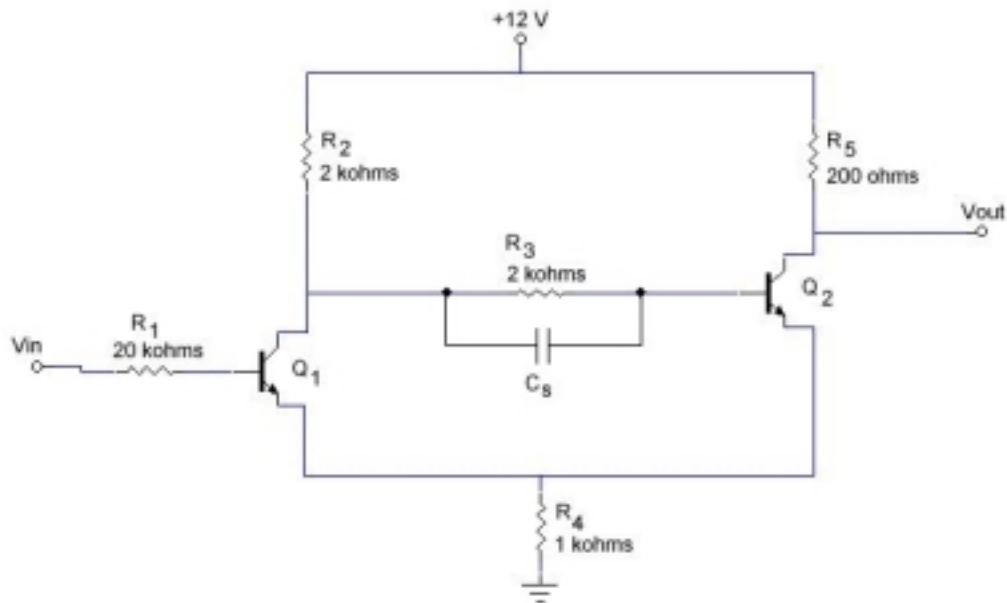

Figure 5

Find the following for the above transistor Schmitt trigger.

a) Determine the:

- Upper Trip Point? $UTP = \underline{10\text{ V}}$

- Lower Trip Point? $LTP = \underline{4\text{ V}}$

- Hysteresis Voltage? $V_H = \underline{6\text{ V}}$

$$UTP = \frac{R_4}{R_4 + R_5} V_{CC} = \frac{1k\Omega}{1k\Omega + 200\Omega} 12V = 10V$$

$$LTP = \frac{R_4}{R_2 + R_4} V_{CC} = \frac{1k\Omega}{2k\Omega + 1k\Omega} 12V = 4V$$

$$V_H = UTP - LTP = 10V - 4V = 6V$$

EE 221 Midterm Solutions

October 30, 2002

Question 5 Continued

b) It is determined that a capacitor can be used in order to increase the switching time.
On the circuit diagram sketch where this capacitor is to be connected.

See C_s on diagram (Figure 5)!

c) If this was a 621 pF capacitor, what would the maximum switching frequency be?

$$F_{\max} = \underline{700 \text{ kHz}}$$

$$C = \frac{t_{re}}{2.3R} \quad t_{re} = \frac{1}{F_{\max}} \quad R = R_3 // R_2 \quad \therefore C = \frac{1}{\frac{2.3R_2R_3}{R_2 + R_3} F_{\max}} = \frac{R_2 + R_3}{2.3R_2R_3F_{\max}}$$

$$\Rightarrow F_{\max} = \frac{R_2 + R_3}{2.3R_2R_3C} = \frac{2k\Omega + 2k\Omega}{2.3 \times 2k\Omega \times 2k\Omega \times 621pF} = 700.13kHz \cong 700kHz$$

d) List two advantages the transistor Schmitt Trigger has over a Basic Transistor Switch.

1) Different trip points for turn on (UTP) and turn off (LTP).

2) The output signal tracks the input signal. i.e. When the input is low the output is low and when the input is high the output is high.

EE 221 Midterm Solutions

October 30, 2002

- 6) (Assume $\beta = 100$, $V_{BE} = 0.7\text{ V}$, $V_{CE(sat)} = 0.3\text{ V}$, and at room temperature ($300\text{ }^\circ\text{K}$))

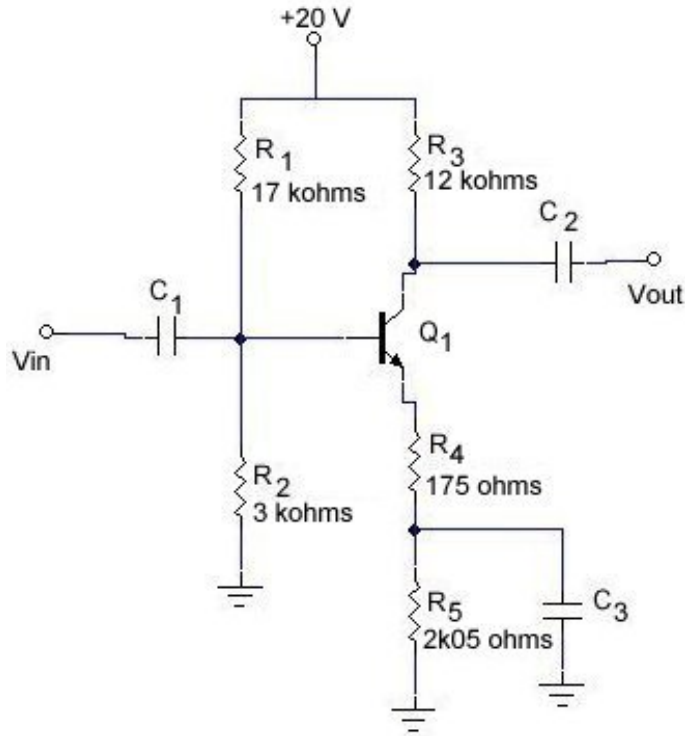
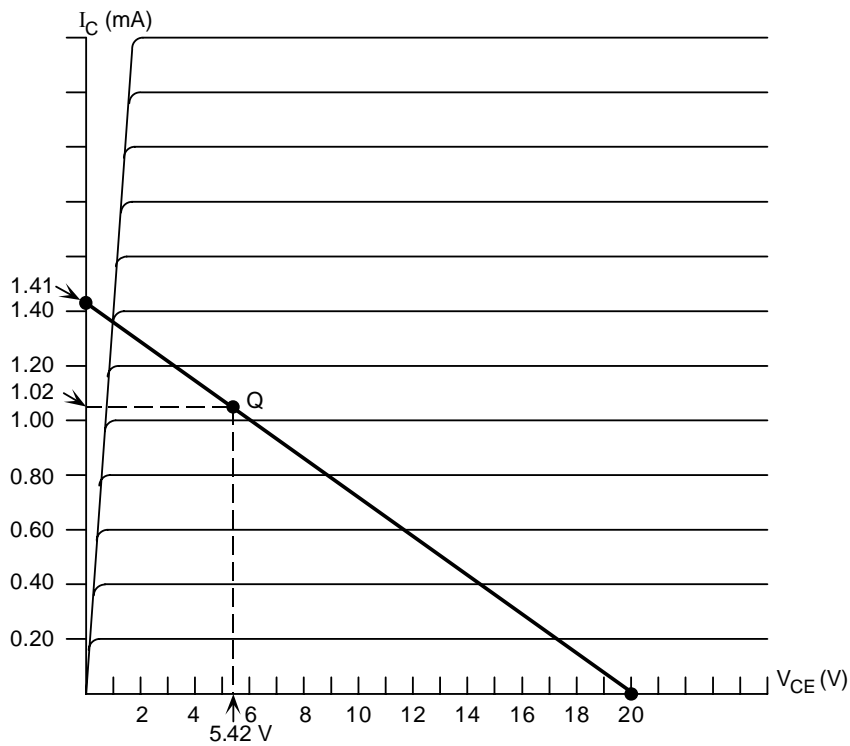

Figure 6

- a) Draw the DC load line and determine the Q point.
 (Use the supplied transistor curve and label the X and Y axis' values)

$I_{CQ} = \underline{1.02\text{ mA}}$

$V_{CEQ} = \underline{5.42\text{ V}}$



EE 221 Midterm Solutions

October 30, 2002

Question 6 Continued Page for Q point calculations

$$I_{C(\max)} = \frac{V_{CC}}{R_3 + R_4 + R_5} = \frac{20V}{12k\Omega + 175\Omega + 2.05k\Omega} = 1.406mA \cong 1.41mA$$

$$V_{BQ} = V_{CC} \frac{R_2}{R_1 + R_2} = 20V \frac{3k\Omega}{17k\Omega + 3k\Omega} = 3V$$

$$V_{EQ} = V_{BQ} - V_{BE} = 3V - 0.7V = 2.3V$$

$$I_{EQ} = \frac{V_{EQ}}{R_4 + R_5} = \frac{2.3V}{175\Omega + 2.05k\Omega} = 1.034mA$$

$$I_{CQ} = \frac{\beta}{\beta + 1} I_{EQ} = \frac{100}{100 + 1} 1.034mA = 1.024mA \cong 1.02mA$$

$$V_{CQ} = V_{CC} - I_{CQ} R_3 = 20V - 1.024mA \times 12k\Omega = 7.72V$$

$$V_{CEQ} = V_{CQ} - V_{EQ} = 7.72V - 2.3V = 5.42V$$

EE 221 Midterm Solutions

October 30, 2002

Question 6 Continued

b) Determine the input impedance (Z_{in}), output impedance (Z_{out}) and voltage gain (A_v).

$$Z_{in} = \underline{2.26 \text{ k}\Omega} \quad Z_{out} = \underline{12 \text{ k}\Omega} \quad A_v = \underline{-60}$$

$$Z_{out} = R_3 = 12 \text{ k}\Omega$$

$$Z_{in} = R_1 // R_2 // \beta(r'e + R_4)$$

$$r'e = \frac{V_T}{I_{EQ}} \quad V_T = \frac{kT}{q} = 0.02585 \text{ V @ room temp. (300}^\circ\text{K)}. \quad \therefore r'e = \frac{0.02585 \text{ V}}{1.034 \text{ mA}} \cong 25 \Omega$$

$$Z_{in} = 17 \text{ k}\Omega // 3 \text{ k}\Omega // 100(25 \Omega + 175 \Omega) = 2.26 \text{ k}\Omega$$

$$A_v = \frac{-R_3}{r'e + R_4} = \frac{-12 \text{ k}\Omega}{25 \Omega + 175 \Omega} = -60$$

EE 221 Midterm Solutions

October 30, 2002

Question 6 Continued

- c) Sketch the T and π transistor ac models for this circuit.
(Remember to label all components)

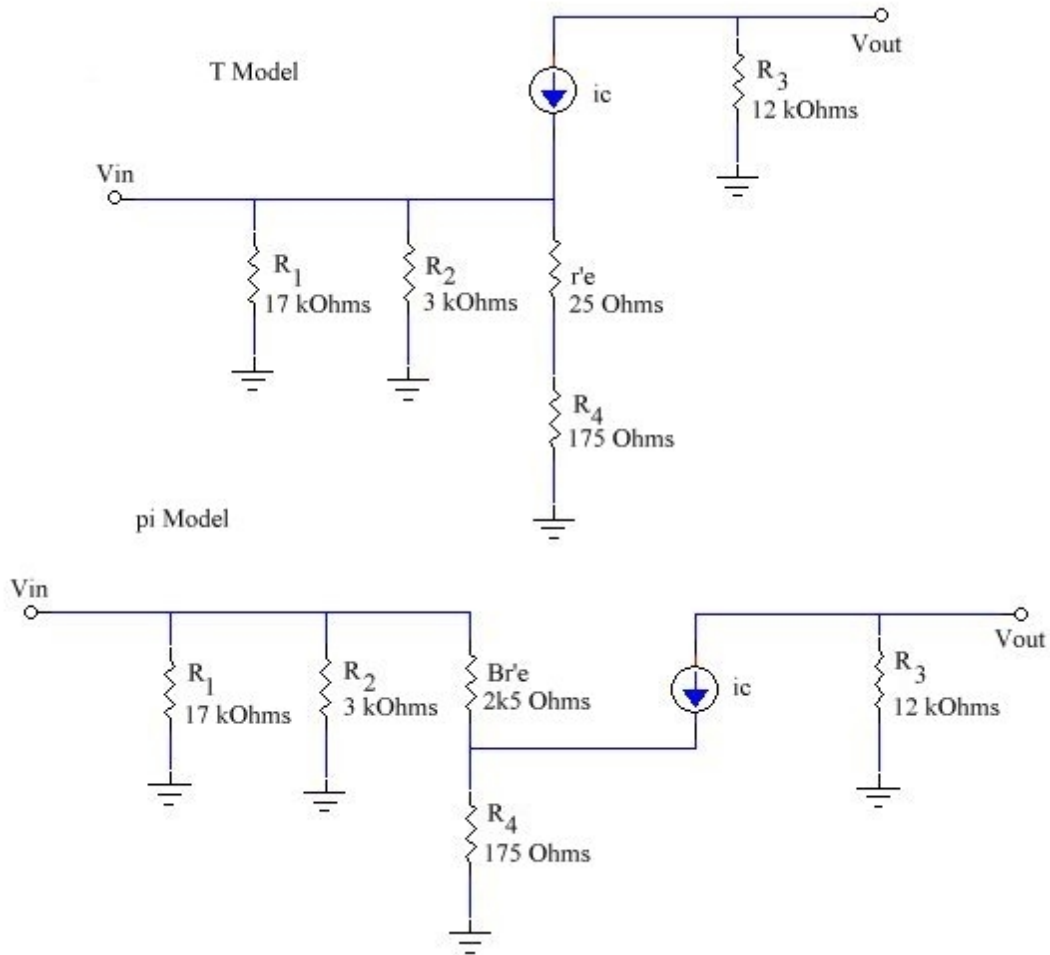

EE 221 Midterm Solutions

October 30, 2002

Question 6 Continued

d) Sketch the DC transistor model for this circuit.

(Remember to label all components)

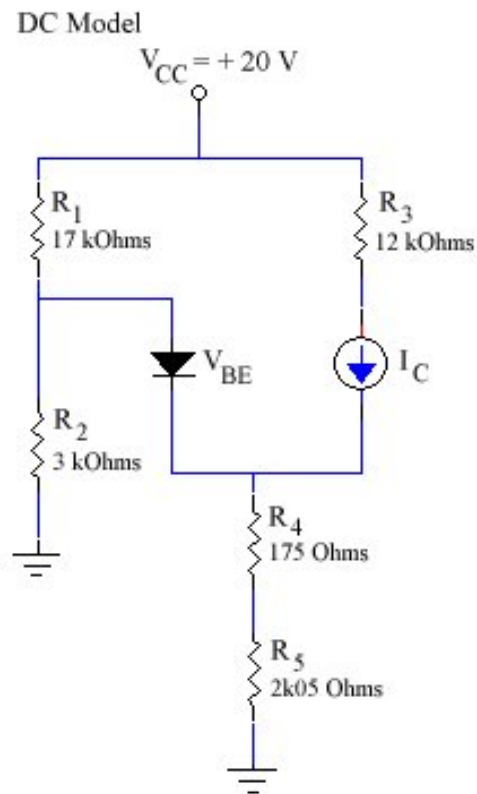

e) Is this a stiff voltage divider bias?

(You must show proof to support your answer)

$$R_1 // R_2 = \frac{17\text{k}\Omega \times 3\text{k}\Omega}{17\text{k}\Omega + 3\text{k}\Omega} = 2.55\text{k}\Omega$$

$$R_E = R_4 + R_5 = 175\Omega + 2.05\text{k}\Omega = 2.225\text{k}\Omega$$

Definition of a stiff voltage divider bias is $R_1 // R_2 < 0.01 \beta R_E$

Since $\beta = 100$ then $0.01 \beta = 1$ and $2.55\text{ k}\Omega$ is **NOT** less than $2.225\text{ k}\Omega$

Therefore this is **NOT** a stiff voltage divider bias.